

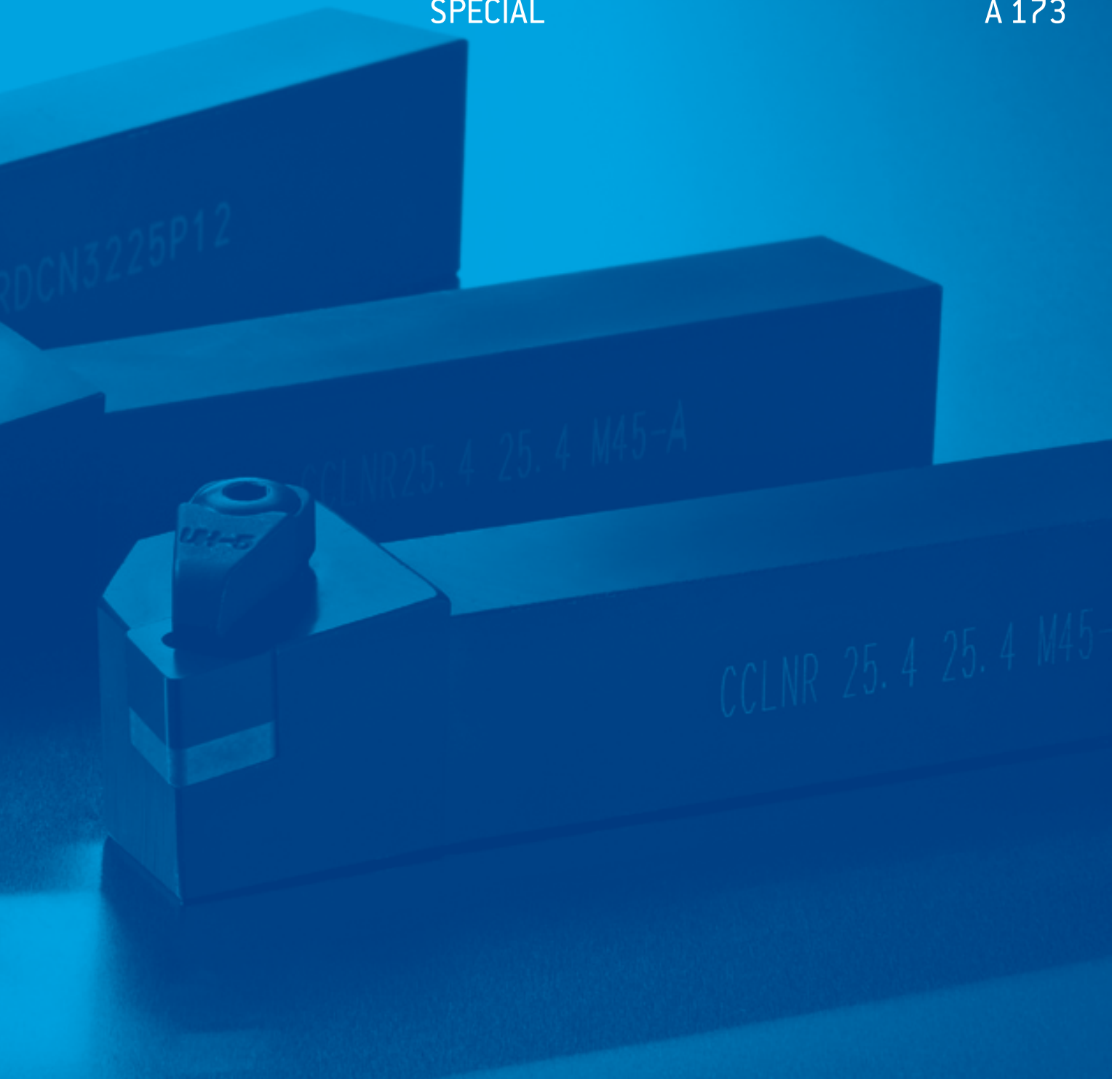

APPLICATION INDEX	A 132
IDENTIFICATION SYSTEM	A 134
EXTERNAL TOOLHOLDER	A 136
SPECIAL	A 173



T O O L H O L D E R

APPLICATION INDEX



CTFP



Page 161

HRCB



Page 162

CVJN



Page 163

CVVN



Page 164

CSBF



Page 165

CSBR



Page 166

CSGF



Page 167

CSGR



Page 168

CSSF



Page 169

CSSR



Page 170

CSSR .. N



Page 171

CWF/R



Page 172

CLKN



Page 173

CFLN



Page 174

CSVN



Page 175

CGVN



Page 176

CINN



Page 177

IDENTIFICATION SYSTEM

C
1

C
2

L
3

N
4

R
5

25
6

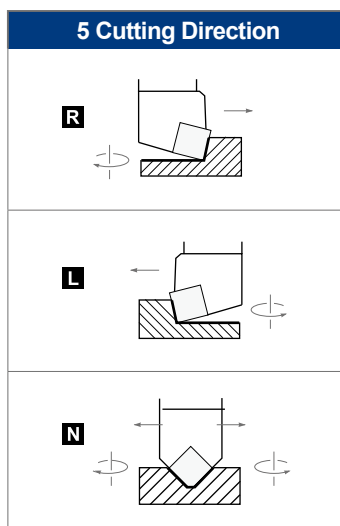
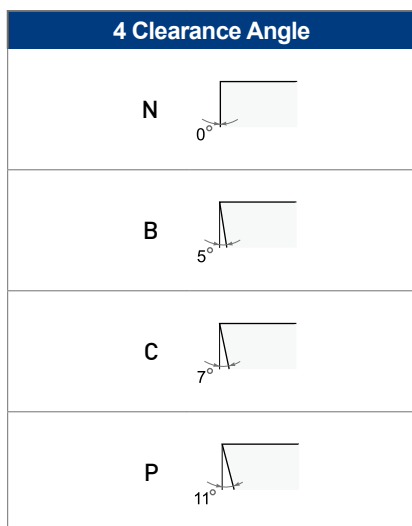
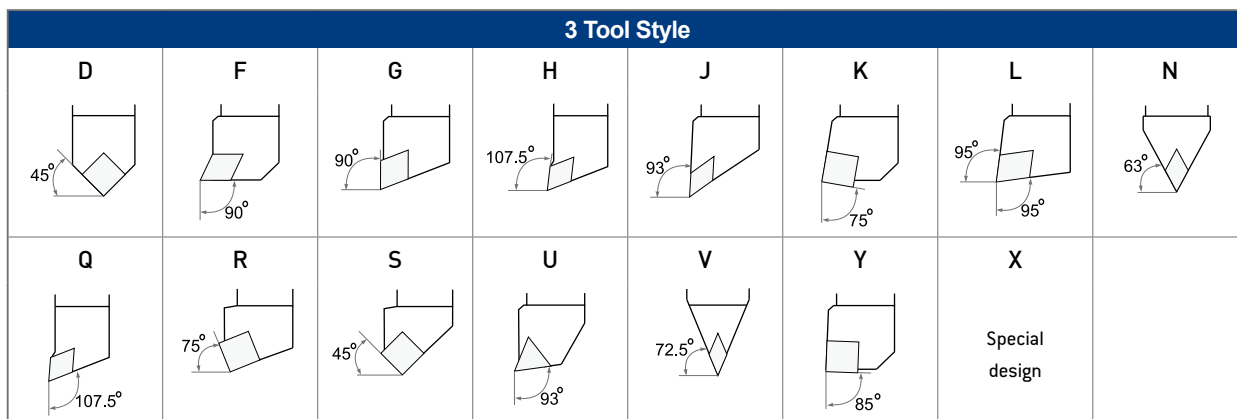
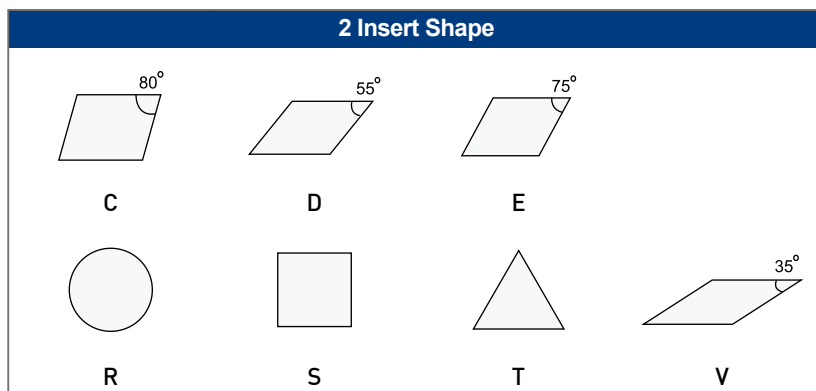
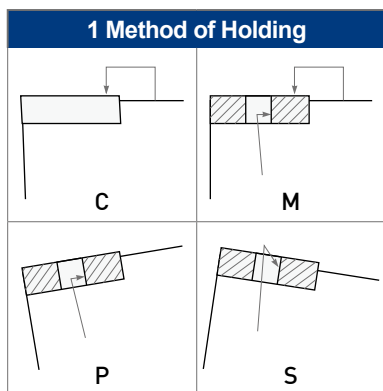

6 Tool Height (h=h₁)

	h (mm)
12	12
16	16
20	20
25	25
32	32
40	40
50	50

25
7

M
8

12
9





-

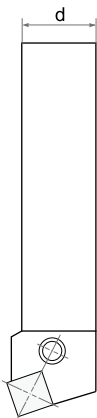

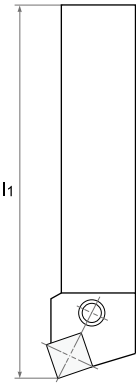
A
10

7
11

7 Tool Width (d)	
	d (mm)
	12
	16
	20
	25
	32
	40
	50

8 Tool Length (l ₁)	
	l ₁ (mm)
	D 60
	E 70
	F 80
	H 100
	K 125
	M 150
	N 160
	P 170
	R 200
	S 250
	T 300
	U 350

9 Insert Size						
Inscribed Circle						
d (mm)	R, S	T (60°)	C (80°)	E (75°)	D (55°)	V (35°)
5.56		09				
6.35	06	11				
7.94	07	13				
9.52	09	16	09		11	16
12.70	12	22	12	13	15	22
15.87	15	27	16		19	
19.05	19	33	19		23	
25.40	25	44	25		31	

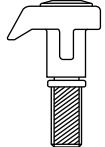
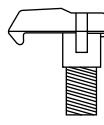
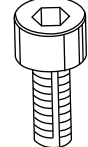
10 Clamping System		
A type	X type	B type
		
+	+	+
		

11 Insert Thickness	
	s
Index	S (mm)
3	3.18
4	4.76
6	6.35
7	7.94
9	9.52

CCLN

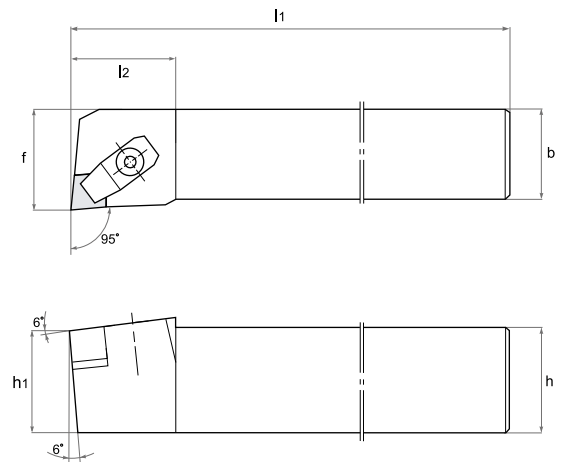

Type	Dimensions [mm]					Stock		Insert	Spare Parts			
	h [h ₁]	b	l ₁	l ₂	f	R	L		Clamp & Clamp Screw	Shim	Shim Screw	Wrench
CCLNR/L 2525M12-A4	25	25	150	35	32	•	•	CNGN1204	UH1	SHCN4A	BM510	LW4
CCLNR/L 2525M12-A7	25	25	150	35	32	•	•	CNGN1207	UH1	SHCN4A	BM510	LW4
CCLNR/L 2525M12-X7	25	25	150	35	32	•	•	CNG(V)X1207	UH5	SHCN4A	BM510	LW4
CCLNR/L 3225P12-A4	32	25	170	35	32	•	•	CNGN1204	UH1	SHCN4A	BM510	LW4
CCLNR/L 3225P12-A7	32	25	170	35	32	•	•	CNGN1207	UH1	SHCN4A	BM510	LW4
CCLNR/L 3225P12-X7	32	25	170	35	32	•	•	CNG(V)X1207	UH5	SHCN4A	BM510	LW4
CCLNR/L 3225P16-X7	32	25	170	35	32	•		CNG(V)X1607	UH5	SHCN5A	FM510	LW4
CCLNR/L 3225P16-A7	32	25	170	35	32			CNGN1607	UH1	SHCN5A	FM510	LW4
CCLNR/L 4040S19-A7	40	40	250	60	50			CNGN1907	UH4	SHCN6A	FM615	LW6
CCLNR/L 5050T25-A9	50	50	300	65	60			CNGN2509	UH25	SHCN8	FM815	LW6

CERAMIC

CERMET

PCBN
/
PCD

TOOL
HOLDER

MILLING
CUTTER

Spare parts													
Clamp & Clamp Screw				Shim				Shim Screw				Wrench	
UH1	UH4	UH5	UH25	SHCN4A	SHCN5A	SHCN6A	SHCN8	BM510	FM510	FM615	FM815	LW4	LW6

CNGN	CNGX	CNVX
Page 26	Page 28	Page 28

EXTERNAL TOOLHOLDER

PART.
A

TURNING
&
MILLING

CCBN

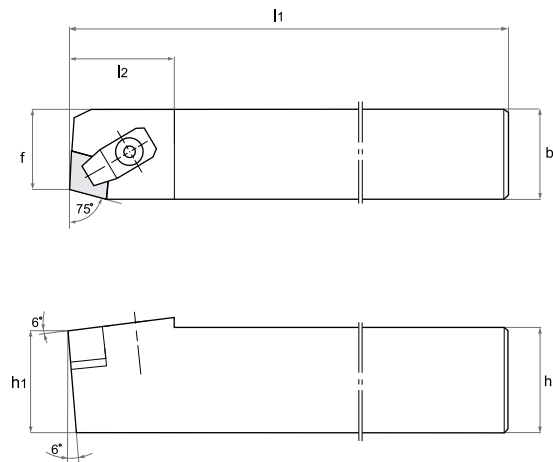
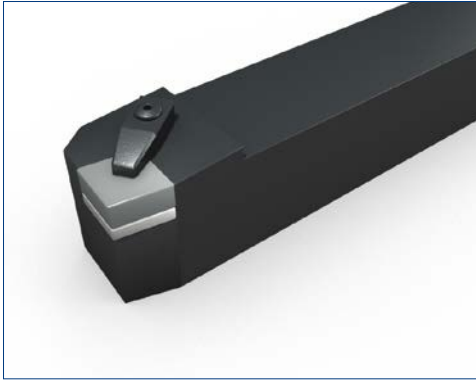

Type	Dimensions (mm)					Stock		Insert	Spare Parts			
	h(h ₁)	b	l ₁	l ₂	f	R	L		Clamp & Clamp Screw	Shim	Shim Screw	Wrench
CCBNR/L 2525M12-A4	25	25	150	35	22		•	CNGN1204	UH1	SHCN4A	BM510	LW4
CCBNR/L 2525M12-A7	25	25	150	35	22	•		CNGN1207	UH1	SHCN4A	BM510	LW4
CCBNR/L 2525M12-X7	25	25	150	35	22			CNG(V)X1207	UH5	SHCN4A	BM510	LW4
CCBNR/L 3225P12-A4	32	25	170	35	22			CNGN1204	UH1	SHCN4A	BM510	LW4
CCBNR/L 3225P12-A7	32	25	170	35	22			CNGN1207	UH1	SHCN4A	BM510	LW4
CCBNR/L 3225P12-X7	32	25	170	35	22			CNG(V)X1207	UH5	SHCN4A	BM510	LW4
CCBNR/L 3225P16-A7	32	25	170	35	27			CNGN1607	UH1	SHCN5A	FM510	LW4
CCBNR/L 3225P16-X7	32	25	170	35	27			CNG(V)X1607	UH5	SHCN5A	FM510	LW4
CCBNR/L 4040S19-A7	40	40	250	60	36			CNGN1907	UH4	SHCN6A	FM615	LW6
CCBNR/L 5050T25-A9	50	50	300	65	45			CNGN2509	UH25	SHCN8	FM815	LW6

Spare parts													
Clamp & Clamp Screw				Shim				Shim Screw				Wrench	
UH1	UH4	UH5	UH25	SHCN4A	SHCN5A	SHCN6A	SHCN8	BM510	FM51	FM615	FM815	LW4	LW6

CNGN	CNGX	CNVX
Page 26	Page 28	Page 28

CERAMIC

CERMET

PCBN
/
PCD

TOOL
HOLDER

MILLING
CUTTER

CCKN

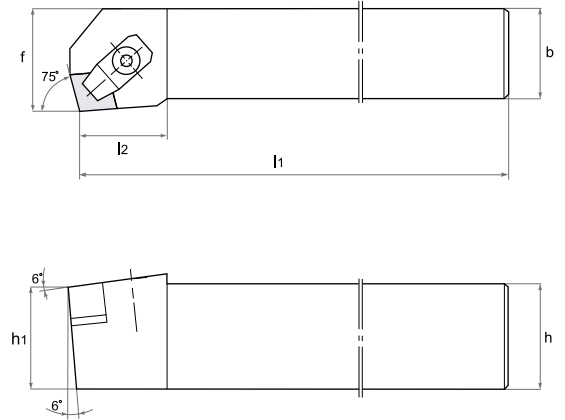
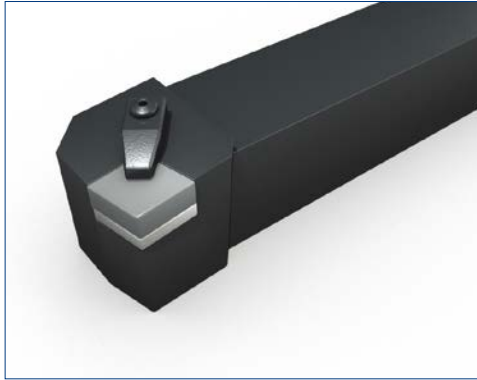

Type	Dimensions [mm]					Stock		Insert	Spare Parts			
	h [h ₁]	b	l ₁	l ₂	f	R	L		Clamp & Clamp Screw	Shim	Shim Screw	Wrench
CCKNR/L 2525M12-A4	25	25	150	29	32			CNGN1204	UH1	SHCN4A	BM510	LW4
CCKNR/L 2525M12-A7	25	25	150	29	32	•	•	CNGN1207	UH1	SHCN4A	BM510	LW4
CCKNR/L 2525M12-X7	25	25	150	29	32	•	•	CNG(V)X1207	UH5	SHCN4A	BM510	LW4
CCKNR/L 3225P12-A4	32	25	170	29	32			CNGN1204	UH1	SHCN4A	BM510	LW4
CCKNR/L 3225P12-A7	32	25	170	29	32		•	CNGN1207	UH1	SHCN4A	BM510	LW4
CCKNR/L 3225P12-X7	32	25	170	29	32	•	•	CNG(V)X1207	UH5	SHCN4A	BM510	LW4

Spare parts					
Clamp & Clamp Screw		Shim		Shim Screw	Wrench
UH1	UH5	SHCN4A		BM510	LW4

CERAMIC

CERMET

PCBN
/
PCD

TOOL
HOLDER

MILLING
CUTTER

CNGN	CNGX	CNVX
Page 26	Page 28	Page 28

EXTERNAL TOOLHOLDER

PART.
A

TURNING
&
MILLING

CDHN

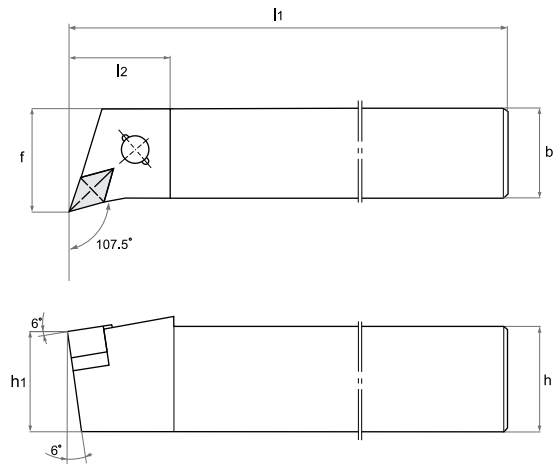

Type	Dimensions (mm)					Stock		Insert	Spare Parts			
	h(h ₁)	b	l ₁	l ₂	f	R	L		Clamp & Clamp Screw	Shim	Shim Screw	Wrench
CDHNR/L 2525M15-A4	25	25	150	33	32	•		DNGN1504	UH1	SHDN4A	BM510	LW4
CDHNR/L 2525M15-A7	25	25	150	33	32	•	•	DNGN1507	UH1	SHDN4A	BM510	LW4
CDHNR/L 2525M12-X7	25	25	150	30	32			DNGX1207	UH5	SHDN3A	TM3507	LW4
CDHNR/L 2525M15-X7	25	25	150	33	32			DNGX1507	UH5	SHDN4A	BM510	LW4
CDHNR/L 3225P15-A4	32	25	170	33	32			DNGN1504	UH1	SHDN4A	BM510	LW4
CDHNR/L 3225P15-A7	32	25	170	33	32			DNGN1507	UH1	SHDN4A	BM510	LW4
CDHNR/L 3225P12-X7	32	25	170	30	32			DNGX1207	UH5	SHDN3A	TM3507	LW4
CDHNR/L 3225P15-X7	32	25	170	33	32			DNGX1507	UH5	SHDN4A	BM510	LW4

Spare parts						
Clamp & Clamp Screw		Shim		Shim Screw		Wrench
UH1	UH5	SHDN3A	SHDN4A	TM3507	BM510	LW4

CERAMIC

CERMET

PCBN
/
PCD

TOOL
HOLDER

MILLING
CUTTER



EXTERNAL TOOLHOLDER

TURNING
&
MILLING

CDJN

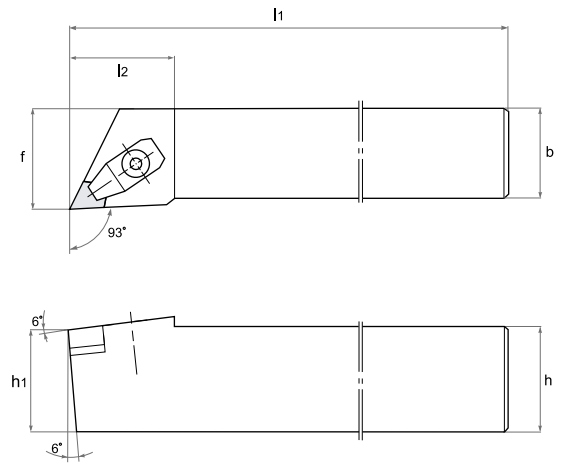

Type	Dimensions [mm]					Stock		Insert	Spare Parts			
	h(h ₁)	b	l ₁	l ₂	f	R	L		Clamp & Clamp Screw	Shim	Shim Screw	Wrench
CDJNR/L 2525M15-A4	25	25	150	38	32	•		DNGN1504	UH1	SHDN4A	BM510	LW4
CDJNR/L 2525M15-A7	25	25	150	38	32	•	•	DNGN1507	UH1	SHDN4A	BM510	LW4
CDJNR/L 2525M12-X7	25	25	150	38	32	•	•	DNGX1207	UH5	SHDN3A	TM3507	LW4
CDJNR/L 2525M15-X7	25	25	150	38	32		•	DNGX1507	UH5	SHDN4A	BM510	LW4
CDJNR/L 3225P15-A4	32	25	170	38	32			DNGN1504	UH1	SHDN4A	BM510	LW4
CDJNR/L 3225P15-A7	32	25	170	38	32	•	•	DNGN1507	UH1	SHDN4A	BM510	LW4
CDJNR/L 3225P12-X7	32	25	170	38	32		•	DNGX1207	UH5	SHDN3A	TM3507	LW4
CDJNR/L 3225P15-X7	32	25	170	38	32	•		DNGX1507	UH5	SHDN4A	BM510	LW4

CERAMIC

CERMET

PCBN
/
PCD

TOOL
HOLDER

MILLING
CUTTER

Spare parts						
Clamp & Clamp Screw		Shim		Shim Screw		Wrench
UH1	UH5	SHDN3A	SHDN4A	TM3507	BM510	LW4

DNGN	DNGX
Page 33	Page 34

EXTERNAL TOOLHOLDER



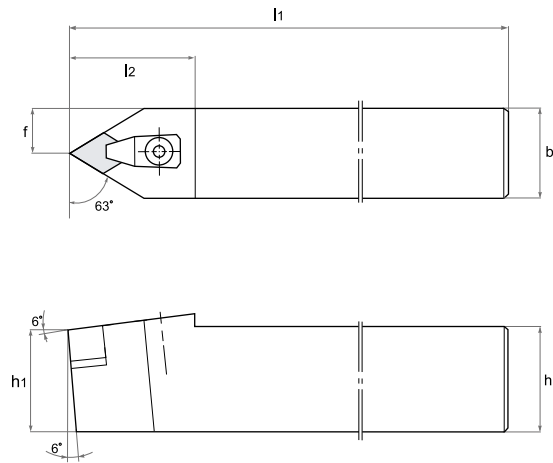

PART.
A

TURNING
&
MILLING

CDNN



Type	Dimensions (mm)					Stock	Insert	Spare Parts			
	h(h ₁)	b	l ₁	l ₂	f			Clamp & Clamp Screw	Shim	Shim Screw	Wrench
CDNN 2525M15-A4	25	25	150	40	12.5		DNGN1504	UH1	SHDN4A	BM510	LW4
CDNN 2525M15-A7	25	25	150	40	12.5		DNGN1507	UH1	SHDN4A	BM510	LW4
CDNN 4025M15-A7	40	25	150	40	12.5		DNGN1507	UH1	SHDN4A	BM510	LW4

Spare parts			
Clamp & Clamp Screw	Shim	Shim Screw	Wrench
			
UH1	SHDN4A	BM510	LW4

CERAMIC

CERMET

PCBN
/
PCD

TOOL
HOLDER

MILLING
CUTTER

DNGN



Page 33

CEFN

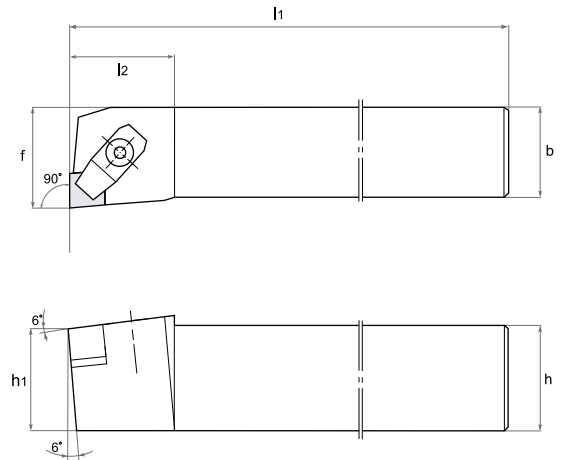
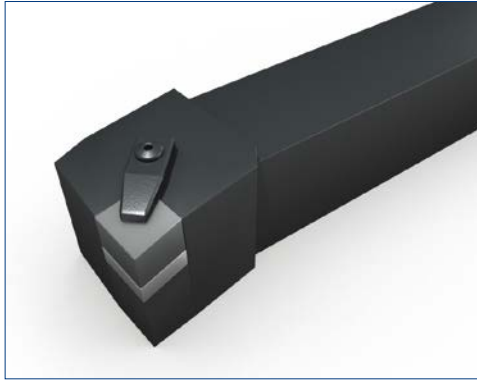

Type	Dimensions [mm]					Stock		Insert	Spare Parts			
	h(h ₁)	b	l ₁	l ₂	f	R	L		Clamp & Clamp Screw	Shim	Shim Screw	Wrench
CEFNR/L 2525M13-A7	25	25	150	29	32			ENGN1307	UH1	SHEN4A	BM510	LW4
CEFNR/L 3225P13-A7	32	25	170	29	32			ENGN1307	UH1	SHEN4A	BM510	LW4

Spare parts			
Clamp & Clamp Screw	Shim	Shim Screw	Wrench
UH1	SHEN4A	BM510	LW4

CERAMIC

CERMET

PCBN
/
PCD

TOOL
HOLDER

MILLING
CUTTER

ENGN



Page 35

EXTERNAL TOOLHOLDER

PART.
A

TURNING
&
MILLING

CEGN

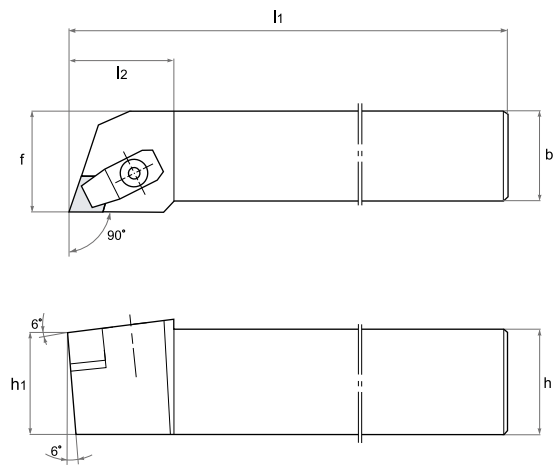
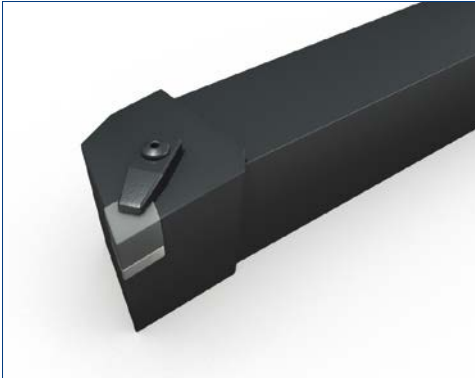

Type	Dimensions (mm)					Stock		Insert	Spare Parts			
	h(h ₁)	b	l ₁	l ₂	f	R	L		Clamp & Clamp Screw	Shim	Shim Screw	Wrench
CEGNR/L 2525M13-A7	25	25	150	23	32			ENG1307	UH1	SHEN4A	BM510	LW4
CEGNR/L 3225P13-A7	32	25	170	23	32	•	•	ENG1307	UH1	SHEN4A	BM510	LW4

Spare parts			
Clamp & Clamp Screw	Shim	Shim Screw	Wrench
UH1	SHEN4A	BM510	LW4

CERAMIC

CERMET

PCBN
/
PCD

TOOL
HOLDER

MILLING
CUTTER

ENGN





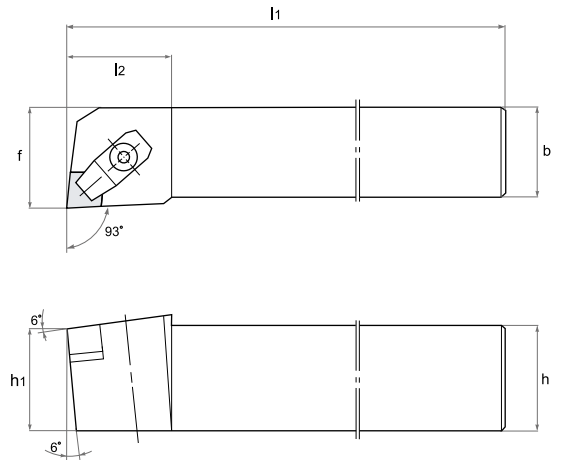

Page 35

CEJN



Type	Dimensions [mm]					Stock		Insert	Spare Parts			
	h(h ₁)	b	l ₁	l ₂	f	R	L		Clamp & Clamp Screw	Shim	Shim Screw	Wrench
CEJNR/L 2525M13-A7	25	25	150	30	32	•	•	ENGN1307	UH1	SHEN4A	BM510	LW4
CEJNR/L 3225P13-A7	32	25	170	30	32			ENGN1307	UH1	SHEN4A	BM510	LW4

Spare parts			
Clamp & Clamp Screw	Shim	Shim Screw	Wrench
			
UH1	SHEN4A	BM510	LW4

CERAMIC

CERMET

PCBN
/
PCD

TOOL
HOLDER

MILLING
CUTTER

ENGN



EXTERNAL TOOLHOLDER

PART.
A

TURNING
&
MILLING

CRDN

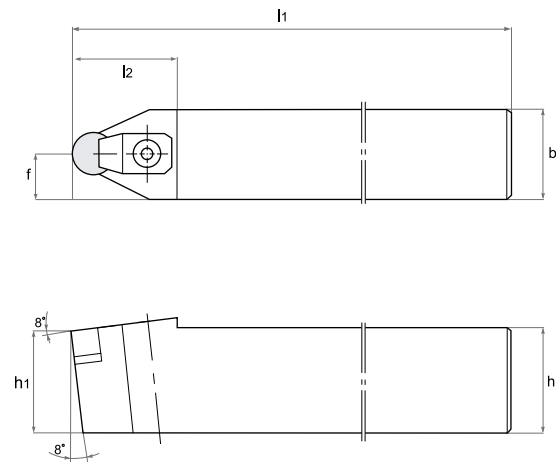

Type	Dimensions (mm)					Stock	Insert	Spare Parts			
	h(h ₁)	b	l ₁	l ₂	f			Clamp & Clamp Screw	Shim	Shim Screw	Wrench
CRDNN 2525M09-A4	25	25	150	32	12.5	●	RNGN0904	UH1	SHRN3A	TM3507	LW4
CRDNN 2525M09-A7	25	25	150	32	12.5	●	RNGN0907	UH1	SHRN3A	TM3507	LW4
CRDNN 2525M12-A4	25	25	150	32	12.5		RNGN1204	UH1	SHRN4A	BM510	LW4
CRDNN 2525M12-A7	25	25	150	32	12.5	●	RNGN1207	UH1	SHRN4A	BM510	LW4
CRDNN 2525M12-X7	25	25	150	32	12.5		RNGX1207	UH5	SHRN4A	BM510	LW4
CRDNN 3225P12-A4	32	25	170	32	12.5		RNGN1204	UH1	SHRN4A	BM510	LW4
CRDNN 3225P12-A7	32	25	170	32	12.5	●	RNGN1207	UH1	SHRN4A	BM510	LW4
CRDNN 3225P12-X7	32	25	170	32	12.5		RNGX1207	UH5	SHRN4A	BM510	LW4
CRDNN 3225P15-A7	32	25	170	32	12.5		RNGN1507	UH1	SHRN5A	BM510	LW4
CRDNN 3225P19-A7	32	25	170	32	12.5	●	RNGN1907	UH4	SHRN6	FM512	LW6

Spare parts											
Clamp & Clamp Screw			Shim				Shim Screw			Wrench	
UH1	UH4	UH5	SHRN3A	SHRN4A	SHRN5A	SHRN6	BM510	TM3507	FM512	LW4	LW6

RNGN	RNGX .. DP
Page 36	Page 38

CERAMIC

CERMET

PCBN
/
PCD

TOOL
HOLDER

MILLING
CUTTER

CRGN

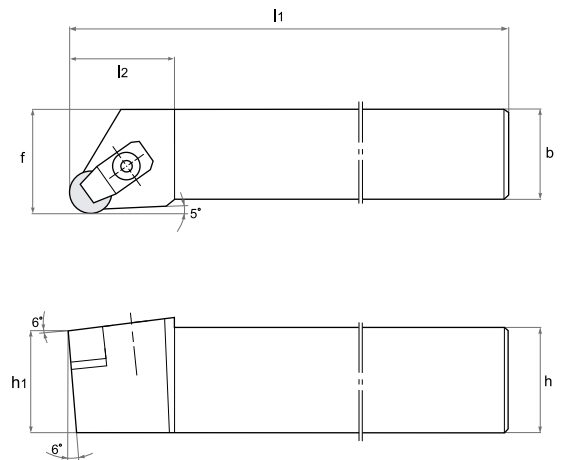
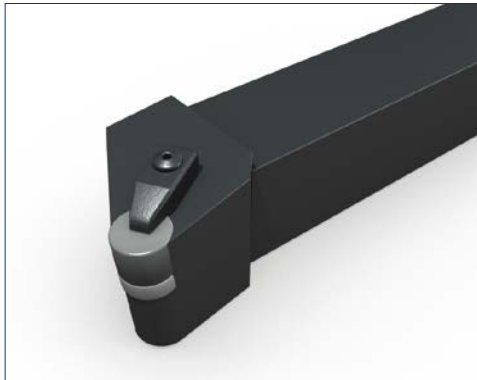

Type	Dimensions [mm]					Stock	Insert	Spare Parts			
	h [h ₁]	b	l ₁	l ₂	f			R	Clamp & Clamp Screw	Shim	Shim Screw
CRGNR/L 2525M09-A4	25	25	150	32	32		RNGN0904	UH1	SHRN3A	TM3507	LW4
CRGNR/L 2525M09-A7	25	25	150	32	32	●	RNGN0907	UH1	SHRN3A	TM3507	LW4
CRGNR/L 2525M12-A4	25	25	150	35	32	●	RNGN1204	UH1	SHRN4A	BM510	LW4
CRGNR/L 2525M12-A7	25	25	150	35	32	●	RNGN1207	UH1	SHRN4A	BM510	LW4
CRGNR/L 2525M12-X7	25	25	150	35	32	●	RNGX1207	UH5	SHRN4A	BM510	LW4
CRGNR/L 3225P12-A4	32	25	170	35	32	●	RNGN1204	UH1	SHRN4A	BM510	LW4
CRGNR/L 3225P12-A7	32	25	170	35	32	●	RNGN1207	UH1	SHRN4A	BM510	LW4
CRGNR/L 3225P12-X7	32	25	170	35	32		RNGX1207	UH5	SHRN4A	BM510	LW4
CRGNR/L 3225P15-A7	32	25	170	37	32	●	RNGN1507	UH1	SHRN5A	BM510	LW4
CRGNR/L 3225P19-A7	32	25	170	45	32	●	RNGN1907	UH4	SHRN6	FM512	LW6

CERAMIC

CERMET

PCBN
/
PCD

TOOL
HOLDER

MILLING
CUTTER

Spare parts											
Clamp & Clamp Screw			Shim				Shim Screw			Wrench	
UH1	UH4	UH5	SHRN3A	SHRN4A	SHRN5A	SHRN6	BM510	TM3507	FM512	LW4	LW6

RNGN	RNGX .. DP
Page 36	Page 38

EXTERNAL TOOLHOLDER

PART.
A

TURNING
&
MILLING

CRDB

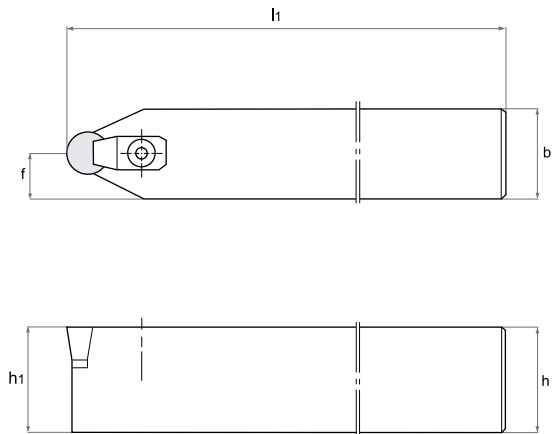

Type	Dimensions (mm)				Stock	Insert	Spare Parts			
	h(h ₁)	b	l ₁	f			Clamp & Clamp Screw	Shim	Shim Screw	Wrench
CRDBN 2525M12-A	25	25	150	12.5	●	RBGX12T	UH1	SHRB12	SH3015	LW4
CRDBN 2525M16-A	25	25	150	12.5	●	RBGX16T	UH1	SHRB16	SH3515	LW4
CRDBN 3232P12-A	32	32	170	16	●	RBGX12T	UH1	SHRB12	SH3015	LW4
CRDBN 3232P16-A	32	32	170	16	●	RBGX16T	UH1	SHRB16	SH3515	LW4
CRDBN 3232P20-A	32	32	170	16		RBGX20T	UH4	SHRB20	SH5015	LW6
CRDBN 3232P26-A	32	32	170	16		RBGX26T	UH4	SHRB26	SH6015	LW6

Spare parts											
Clamp & Clamp Screw		Shim				Shim Screw				Wrench	
UH1	UH4	SHRB12	SHRB16	SHRB20	SHRB26	SH3015	SH3515	SH5015	SH6015	LW4	LW6

CERAMIC

CERMET

PCBN
/
PCD

TOOL
HOLDER

MILLING
CUTTER

RBGX



Page 56

CRDC

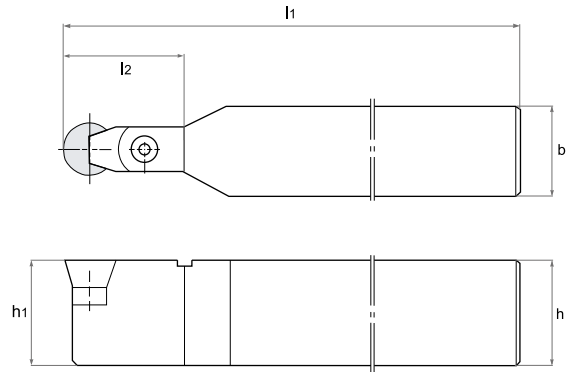
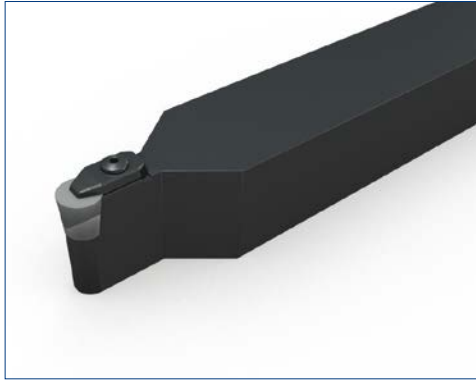

Type	Dimensions [mm]				Stock	Insert	Spare Parts			
	h(h ₁)	b	l ₁	l ₂			Clamp & Clamp Screw	Shim	Shim Screw	Wrench
CRDCN 3225P06-A4	32	25	170	20	●	RCGX0604	CLRC6	SHRC102	-	LW3
CRDCN 3225P06-A6	32	25	170	20	●	RCGX0606	CLRC6	SHRC102	-	LW3
CRDCN 3225P06-A7	32	25	170	20	●	RCGX0607	CLRC6	SHRC102	-	LW3
CRDCN 3225P09-A7	32	25	170	20	●	RCGX0907	CLRC9	SHRC103	FM315	LW4
CRDCN 3225P12-A7	32	25	170	20	●	RCGX1207	UH1	SHRC104	FM415	LW4
CRDCN 5040T12-A7	50	40	300	30	●	RCGX1207	UH1	SHRC104	FM415	LW4
CRDCN 5040T15-A10	50	40	300	35	●	RCGX1510	UH1	SHRC105	FM415	LW4
CRDCN 5040T19-A10	50	40	300	45		RCGX1910	UH4	SHRC106	FM415	LW6
CRDCN 5040T25-A12	50	40	300	50		RCGX2512	UH25	SHRC108	FM615	LW6

CERAMIC

Spare parts										
Clamp & Clamp Screw			Shim			Shim Screw		Wrench		
CLRC6	CLRC9	UH25	SHRC102	SHRC103	SHRC104	FM210	FM315	LW3	LW4	LW6
UH1	UH4		SHRC105	SHRC106	SHRC108	FM415	FM615			

CERMET

PCBN
/
PCD

TOOL
HOLDER



MILLING
CUTTER

EXTERNAL TOOLHOLDER

PART.
A

TURNING
&
MILLING

CSBN

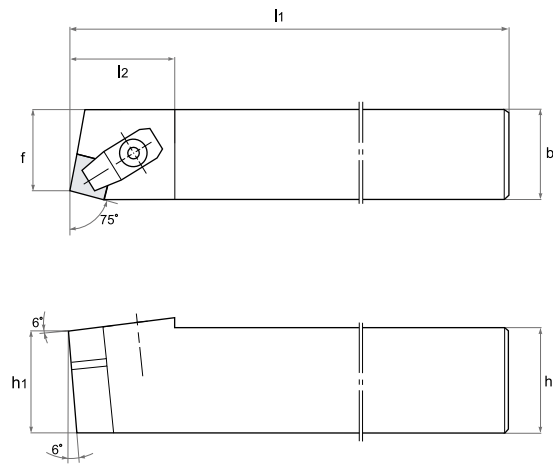

Type	Dimensions (mm)					Stock		Insert	Spare Parts			
	h(h ₁)	b	l ₁	l ₂	f	R	L		Clamp & Clamp Screw	Shim	Shim Screw	Wrench
CSBNR/L 2525M12-A4	25	25	150	34	22	•	•	SNGN1204	UH1	SHSN4A	BM510	LW4
CSBNR/L 2525M12-A7	25	25	150	34	22	•	•	SNGN1207	UH1	SHSN4A	BM510	LW4
CSBNR/L 2525M12-X7	25	25	150	34	22	•		SNGX1207	UH5	SHSN4A	BM510	LW4
CSBNR/L 2525M15-A7	25	25	150	34	22			SNGN1507	UH1	SHSN5A	FM512	LW4
CSBNR/L 2525M15-X7	25	25	150	40	22			SNGX1507	UH5	SHSN5A	FM512	LW4
CSBNR/L 3225P12-A7	32	25	170	34	22	•	•	SNGN1207	UH1	SHSN4A	BM510	LW4
CSBNR/L 3225P12-X7	32	25	170	34	22	•		SNGX1207	UH5	SHSN4A	BM510	LW4
CSBNR/L 3225P15-A7	32	25	170	40	22	•		SNGN1507	UH1	SHSN5A	FM512	LW4
CSBNR/L 3225P15-X7	32	25	170	40	22			SNGX1507	UH5	SHSN5A	FM512	LW4
CSBNR/L 4040S19-A7	40	40	250	54	35			SNGN1907	UH4	SHSN6A	FM612	LW6
CSBNR/L 5050T25-A9	50	50	300	65	45			SNGN2509	UH25	SHSN8	FM815	LW6

Spare parts											
Clamp & Clamp Screw				Shim		Shim Screw			Wrench		
UH1	UH4	UH5	UH25	SHSN4A SHSN6A	SHSN5A SHSN8	BM510	FM512 FM815	FM612	LW4	LW6	



CERAMIC

CERMET

PCBN
/
PCD

TOOL
HOLDER

MILLING
CUTTER

CSDN

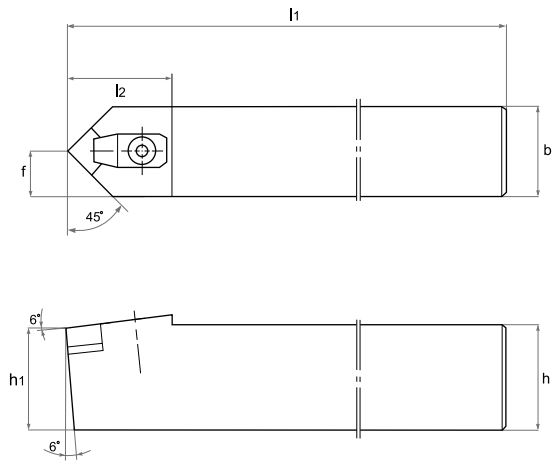

Type	Dimensions [mm]					Stock	Insert	Spare Parts			
	h(h ₁)	b	l ₁	l ₂	f			R	Clamp & Clamp Screw	Shim	Shim Screw
CSDNN 2525M12-A4	25	25	150	35	12.5	•	SNGN1204	UH1	SHSN4A	BM510	LW4
CSDNN 2525M12-A7	25	25	150	35	12.5	•	SNGN1207	UH1	SHSN4A	BM510	LW4
CSDNN 2525M12-X7	25	25	150	35	12.5		SNGX1207	UH5	SHSN4A	BM510	LW4
CSDNN 2525M15-A7	25	25	150	38	12.5		SNGN1507	UH1	SHSN5A	FM512	LW4
CSDNN 2525M15-X7	25	25	150	38	12.5		SNGX1507	UH5	SHSN5A	FM512	LW4
CSDNN 3225P12-A7	32	25	170	35	12.5	•	SNGN1207	UH1	SHSN4A	BM510	LW4
CSDNN 3225P12-X7	32	25	170	35	12.5		SNGX1207	UH5	SHSN4A	BM510	LW4
CSDNN 3225P15-A7	32	25	170	38	12.5	•	SNGN1507	UH1	SHSN5A	FM512	LW4
CSDNN 3225P15-X7	32	25	170	38	12.5		SNGX1507	UH5	SHSN5A	FM512	LW4
CSDNN 4040S19-A7	40	40	250	60	20	•	SNGN1907	UH4	SHSN6A	FM612	LW6
CSDNN 5050T25-A9	50	50	300	60	25	•	SNGN2509	UH25	SHSN8	FM815	LW6

CERAMIC

CERMET

PCBN
/
PCD

TOOL
HOLDER

MILLING
CUTTER

Spare parts										
Clamp & Clamp Screw				Shim		Shim Screw			Wrench	
UH1	UH4	UH5	UH25	SHSN4A SHSN6A	SHSN5A SHSN8	BM510	FM512 FM815	FM612	LW4	LW6

SNGN	SNGX
Page 41	Page 42

EXTERNAL TOOLHOLDER

PART.
A

TURNING
&
MILLING

CSKN

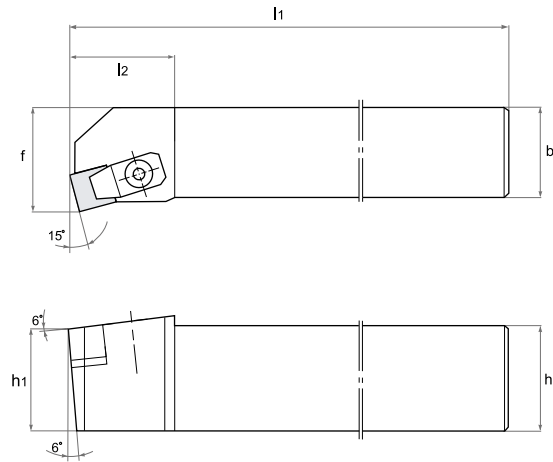

Type	Dimensions (mm)					Stock		Insert	Spare Parts			
	h(h _i)	b	l ₁	l ₂	f	R	L		Clamp & Clamp Screw	Shim	Shim Screw	Wrench
CSKNR/L 2525M12-A4	25	25	150	34	32			SNGN1204	UH1	SHSN4A	BM510	LW4
CSKNR/L 2525M12-A7	25	25	150	34	32	•	•	SNGN1207	UH1	SHSN4A	BM510	LW4
CSKNR/L 2525M12-X7	25	25	150	34	32	•	•	SNGX1207	UH5	SHSN4A	BM510	LW4
CSKNR/L 2525M15-A7	25	25	150	40	32			SNGN1507	UH1	SHSN5A	FM512	LW4
CSKNR/L 2525M15-X7	25	25	150	40	32			SNGX1507	UH5	SHSN5A	FM512	LW4
CSKNR/L 3225P12-A7	32	25	170	34	32			SNGN1207	UH1	SHSN4A	BM510	LW4
CSKNR/L 3225P12-X7	32	25	170	34	32		•	SNGX1207	UH5	SHSN4A	BM510	LW4
CSKNR/L 3225P15-A7	32	25	170	40	32	•	•	SNGN1507	UH1	SHSN5A	FM512	LW4
CSKNR/L 3225P15-X7	32	25	170	40	32			SNGX1507	UH5	SHSN5A	FM512	LW4

Spare parts						
Clamp & Clamp Screw		Shim		Shim Screw		Wrench
UH1	UH5	SHSN4A	SHSN5A	BM510	FM512	LW4

SNGN	SNGX
Page 41	Page 42

CERAMIC

CERMET

PCBN
/
PCD

TOOL
HOLDER

MILLING
CUTTER

CSRNR

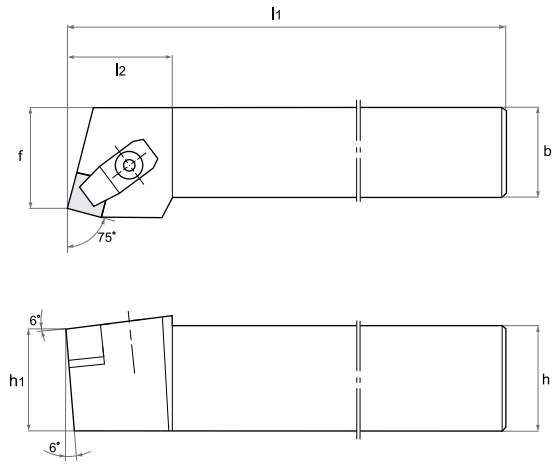
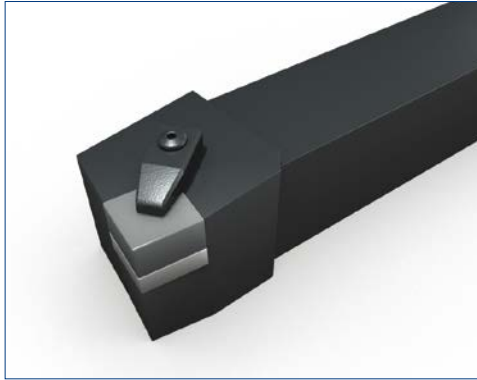

Type	Dimensions [mm]					Stock		Insert	Spare Parts			
	h(h ₁)	b	l ₁	l ₂	f	R	L		Clamp & Clamp Screw	Shim	Shim Screw	Wrench
CSRNR/L 2525M12-A4	25	25	150	32	27	•	•	SNGN1204	UH1	SHSN4A	BM510	LW4
CSRNR/L 2525M12-A7	25	25	150	32	27	•	•	SNGN1207	UH1	SHSN4A	BM510	LW4
CSRNR/L 2525M12-X7	25	25	150	32	27	•		SNGX1207	UH5	SHSN4A	BM510	LW4
CSRNR/L 2525M15-A7	25	25	150	34	27			SNGN1507	UH1	SHSN5A	FM512	LW4
CSRNR/L 2525M15-X7	25	25	150	34	27			SNGX1507	UH5	SHSN5A	FM512	LW4
CSRNR/L 3225P12-A7	32	25	170	32	27			SNGN1207	UH1	SHSN4A	BM510	LW4
CSRNR/L 3225P12-X7	32	25	170	32	27			SNGX1207	UH5	SHSN4A	BM510	LW4
CSRNR/L 3225P15-A7	32	25	170	34	27	•	•	SNGN1507	UH1	SHSN5A	FM512	LW4
CSRNR/L 3225P15-X7	32	25	170	34	27	•		SNGX1507	UH5	SHSN5A	FM512	LW4
CSRNR/L 4040S19-A7	40	40	250	54	43			SNGN1907	UH4	SHSN6A	FM612	LW6
CSRNR/L 5050T25-A9	50	50	300	70	53			SNGN2509	UH25	SHSN8	FM815	LW6

CERAMIC

CERMET

PCBN
/
PCD

**TOOL
HOLDER**

MILLING
CUTTER

Spare parts										
Clamp & Clamp Screw				Shim		Shim Screw			Wrench	
UH1	UH4	UH5	UH25	SHSN4A SHSN6A	SHSN5A SHSN8	BM510	FM512 FM815	FM612	LW4	LW6

SNGN	SNGX
Page 41	Page 42

EXTERNAL TOOLHOLDER

PART.
A

TURNING
&
MILLING

CSSNR

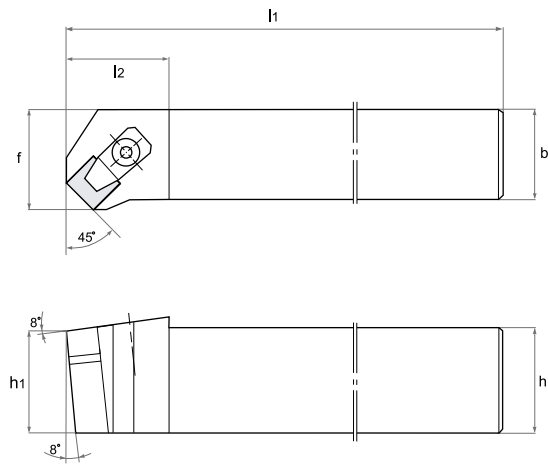

Type	Dimensions (mm)					Stock		Insert	Spare Parts			
	h(h _i)	b	l ₁	l ₂	f	R	L		Clamp & Clamp Screw	Shim	Shim Screw	Wrench
CSSNR/L 2525M12-A4	25	25	150	35	32			SNGN1204	UH1	SHSN4A	BM510	LW4
CSSNR/L 2525M12-A7	25	25	150	35	32	•	•	SNGN1207	UH1	SHSN4A	BM510	LW4
CSSNR/L 2525M12-X7	25	25	150	35	32		•	SNGX1207	UH5	SHSN4A	BM510	LW4
CSSNR/L 2525M15-A7	25	25	150	37	32	•		SNGN1507	UH1	SHSN5A	FM512	LW4
CSSNR/L 2525M15-X7	25	25	150	37	32			SNGX1507	UH5	SHSN5A	FM512	LW4
CSSNR/L 3225P12-A7	32	25	170	35	32	•		SNGN1207	UH1	SHSN4A	BM510	LW4
CSSNR/L 3225P12-X7	32	25	170	35	32			SNGX1207	UH5	SHSN4A	BM510	LW4
CSSNR/L 3225P15-A7	32	25	170	37	32			SNGN1507	UH1	SHSN5A	FM512	LW4
CSSNR/L 3225P15-X7	32	25	170	37	32			SNGX1507	UH5	SHSN5A	FM512	LW4

Spare parts						
Clamp & Clamp Screw		Shim		Shim Screw		Wrench
UH1	UH5	SHSN4A	SHSN5A	BM510	FM512	LW4

SNGN	SNGX
Page 41	Page 42

CERAMIC

CERMET

PCBN
/
PCD

TOOL
HOLDER

MILLING
CUTTER

CSYN

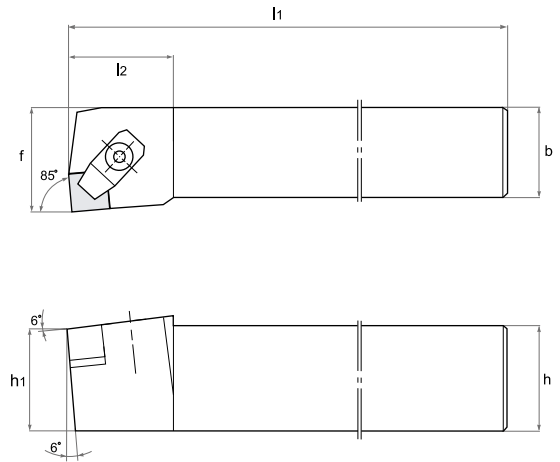
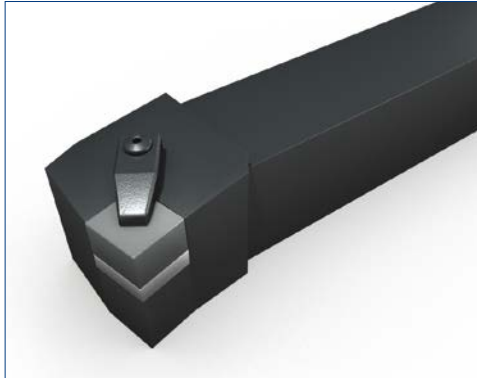

Type	Dimensions [mm]					Stock		Insert	Spare Parts			
	h(h ₁)	b	l ₁	l ₂	f	R	L		Clamp & Clamp Screw	Shim	Shim Screw	Wrench
CSYNR/L 2525M12-A4	25	25	150	27	32	•		SNGN1204	UH1	SHSN4A	BM510	LW4
CSYNR/L 2525M12-A7	25	25	150	27	32	•		SNGN1207	UH1	SHSN4A	BM510	LW4
CSYNR/L 2525M12-X7	25	25	150	27	32			SNGX1207	UH5	SHSN4A	BM510	LW4
CSYNR/L 2525M15-A7	25	25	150	27	32			SNGN1507	UH1	SHSN5A	FM512	LW4
CSYNR/L 2525M15-X7	25	25	150	27	32			SNGX1507	UH5	SHSN5A	FM512	LW4
CSYNR/L 3225P12-A7	32	25	170	27	32			SNGN1207	UH1	SHSN4A	BM510	LW4
CSYNR/L 3225P12-X7	32	25	170	27	32			SNGX1207	UH5	SHSN4A	BM510	LW4
CSYNR/L 3225P15-A7	32	25	170	27	32			SNGN1507	UH1	SHSN5A	FM512	LW4
CSYNR/L 3225P15-X7	32	25	170	27	32			SNGX1507	UH5	SHSN5A	FM512	LW4

CERAMIC

CERMET

PCBN
/
PCD

TOOL
HOLDER

MILLING
CUTTER

Spare parts						
Clamp & Clamp Screw		Shim		Shim Screw		Wrench
UH1	UH5	SHSN4A	SHSN5A	BM510	FM512	LW4

SNGN	SNGX
Page 41	Page 42

EXTERNAL TOOLHOLDER





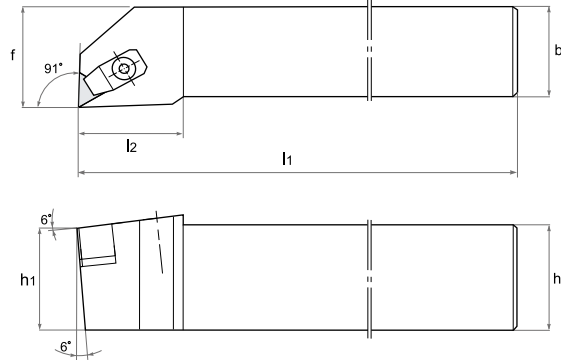

PART.
A

CTFN



TURNING
&
MILLING

Type	Dimensions (mm)					Stock		Insert	Spare Parts			
	h(h ₁)	b	l ₁	l ₂	f	R	L		Clamp & Clamp Screw	Shim	Shim Screw	Wrench
CTFNR/L 2525M16-A4	25	25	150	29	32			TNGN1604	UH1	SHTN3A	BM408	LW4
CTFNR/L 2525M16-A7	25	25	150	29	32			TNGN1607	UH1	SHTN3A	BM408	LW4
CTFNR/L 2525M22-A4	25	25	150	32	32			TNGN2204	UH1	SHTN4	FM410	LW4
CTFNR/L 2525M22-A7	25	25	150	32	32	•		TNGN2207	UH1	SHTN4	FM410	LW4
CTFNR/L 3225P16-A4	32	25	170	29	32			TNGN1604	UH1	SHTN3A	BM408	LW4
CTFNR/L 3225P16-A7	32	25	170	29	32			TNGN1607	UH1	SHTN3A	BM408	LW4
CTFNR/L 3225P22-A4	32	25	170	32	32			TNGN2204	UH1	SHTN4	FM410	LW4
CTFNR/L 3225P22-A7	32	25	170	32	32			TNGN2207	UH1	SHTN4	FM410	LW4

Spare parts					
Clamp & Clamp Screw	Shim		Shim Screw		Wrench
					
UH1	SHTN3A	SHTN4A	BM408	FM410	LW4

CERAMIC

CERMET

PCBN
/
PCD

TOOL
HOLDER

MILLING
CUTTER

TNGN



Page 46

CTGN

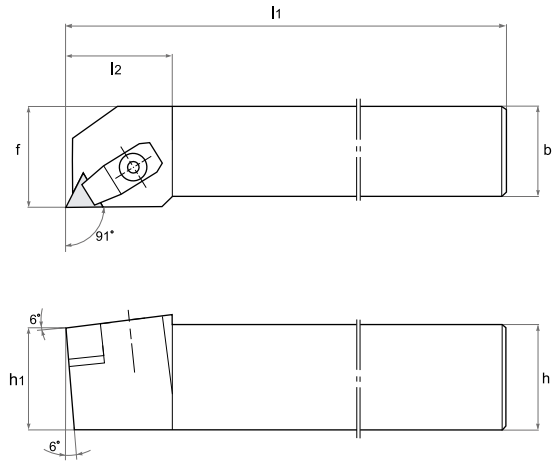
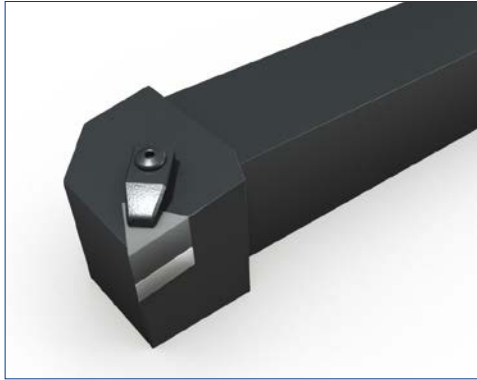

Type	Dimensions [mm]					Stock		Insert	Spare Parts			
	h [h ₁]	b	l ₁	l ₂	f	R	L		Clamp & Clamp Screw	Shim	Shim Screw	Wrench
CTGNR/L 2525M16-A4	25	25	150	26	32	•	•	TNGN1604	UH1	SHTN3A	BM408	LW4
CTGNR/L 2525M16-A7	25	25	150	26	32		•	TNGN1607	UH1	SHTN3A	BM408	LW4
CTGNR/L 2525M22-A4	25	25	150	26	32	•		TNGN2204	UH1	SHTN4	FM410	LW4
CTGNR/L 2525M22-A7	25	25	150	26	32			TNGN2207	UH1	SHTN4	FM410	LW4
CTGNR/L 3225P16-A4	32	25	170	26	32	•	•	TNGN1604	UH1	SHTN3A	BM408	LW4
CTGNR/L 3225P16-A7	32	25	170	26	32			TNGN1607	UH1	SHTN3A	BM408	LW4
CTGNR/L 3225P22-A4	32	25	170	26	32			TNGN2204	UH1	SHTN4	FM410	LW4
CTGNR/L 3225P22-A7	32	25	170	26	32			TNGN2207	UH1	SHTN4	FM410	LW4





CERAMIC

CERMET

PCBN
/
PCD

TOOL
HOLDER

MILLING
CUTTER

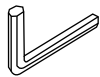
Spare parts					
Clamp & Clamp Screw	Shim		Shim Screw		Wrench
					
UH1	SHTN3A	SHTN4A	BM408	FM410	LW4



EXTERNAL TOOLHOLDER



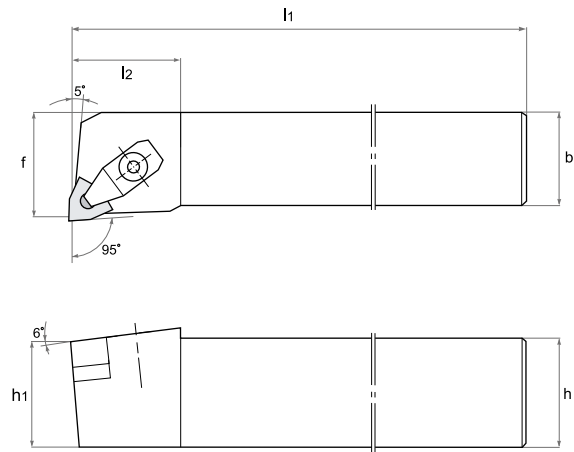
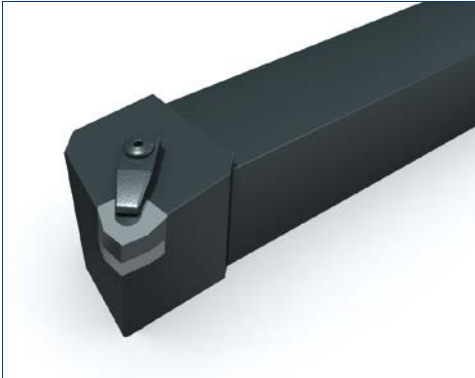

PART.
A

TURNING
&
MILLING

CWLN

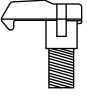

Type	Dimensions (mm)					Stock		Insert	Spare Parts			
	h(h ₁)	b	l ₁	l ₂	f	R	L		Clamp & Clamp Screw	Shim	Shim Screw	Wrench
CWLN/L 2525M08-X7	25	25	150	28	32	•	•	WNGX0807	UH5	SHWN4A	TM4010	LW4
CWLN/L 3225M08-X7	32	25	150	28	32	•	•	WNGX0807	UH5	SHWN4A	TM4010	LW4

Spare parts			
Clamp & Clamp Screw	Shim	Shim Screw	Wrench
			
UH5	SHWN4A	TM4010	LW4

CERAMIC

CERMET

PCBN
/
PCD

TOOL
HOLDER

MILLING
CUTTER

WNGX





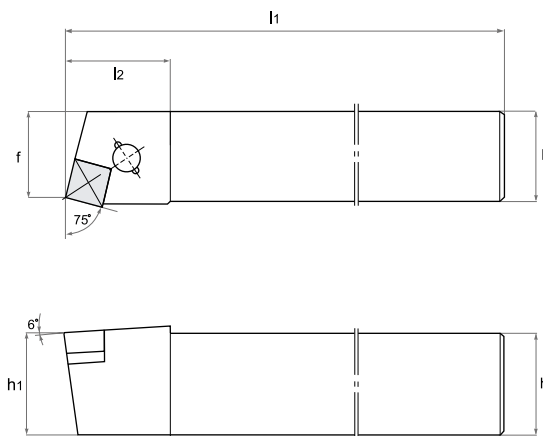

Page 51

CSRC



Type	Dimensions [mm]					Stock		Insert	Spare Parts			
	$h(h_1)$	b	l_1	l_2	f	R	L		Clamp & Clamp Screw	Shim	Shim Screw	Wrench
CSRCR/L 2525M12-A4	25	25	150	32	27	•		SCGN1204	UH1	SHSC4A	SP3	LW4
CSRCR/L 3225P12-A4	32	25	170	32	27			SCGN1204	UH1	SHSC4A	SP3	LW4

Spare parts			
Clamp & Clamp Screw	Shim	Shim Screw	Wrench
			
UH1	SHSC4A	SP3	LW4

CERAMIC

CERMET

PCBN
/
PCD

TOOL
HOLDER

MILLING
CUTTER

SCGN



Page 43

EXTERNAL TOOLHOLDER

PART.
A

TURNING
&
MILLING

CSSC

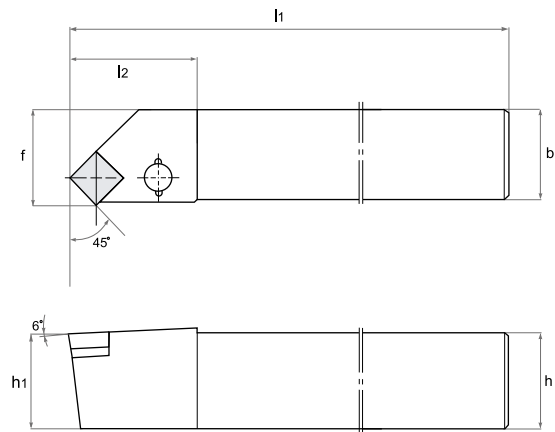

Type	Dimensions (mm)					Stock		Insert	Spare Parts			
	h(h ₁)	b	l ₁	l ₂	f	R	L		Clamp & Clamp Screw	Shim	Shim Screw	Wrench
CSSCR/L 2525M12-A4	25	25	150	35	32	•		SCGN1204	UH1	SHSC4A	SP3	LW4
CSSCR/L 2525M12-A6	25	25	150	35	32			SCGN1206	UH1	SHSC4A	SP3	LW4
CSSCR/L 3225P12-A4	32	25	170	35	32			SCGN1204	UH1	SHSC4A	SP3	LW4
CSSCR/L 3225P12-A6	32	25	170	35	32			SCGN1206	UH1	SHSC4A	SP3	LW4

Spare parts			
Clamp & Clamp Screw	Shim	Shim Screw	Wrench
UH1	SHSC4A	SP3	LW4

CERAMIC

CERMET

PCBN
/
PCD

TOOL
HOLDER

MILLING
CUTTER

SCGN



Page 43

CSTP

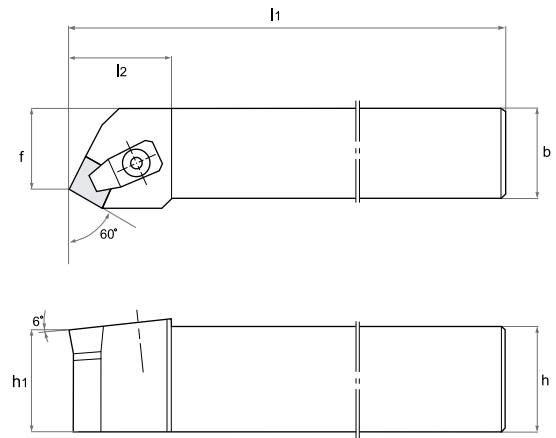

Type	Dimensions [mm]					Stock		Insert	Spare Parts			
	h [h ₁]	b	l ₁	l ₂	f	R	L		Clamp & Clamp Screw	Shim	Shim Screw	Wrench
CSTPR/L 2020K09-A3	20	20	125	24	17			SPGN0903	UH1	SHSC3A	SP3	LW4
CSTPR/L 2020K12-A3	20	20	125	30	17			SPGN1203	UH1	SHSC4A	SP3	LW4
CSTPR/L 2020K12-A4	20	20	125	30	17			SPGN1204	UH1	SHSC4A	SP3	LW4
CSTPR/L 2525M12-A3	25	25	150	30	22			SPGN1203	UH1	SHSC4A	SP3	LW4
CSTPR/L 2525M12-A4	25	25	150	30	22			SPGN1204	UH1	SHSC4A	SP3	LW4

Spare parts				
Clamp & Clamp Screw	Shim		Shim Screw	Wrench
UH1	SHSC3A	SHSC4A	SP3	LW4

CERAMIC

CERMET

PCBN
/
PCD

TOOL
HOLDER

MILLING
CUTTER

SPGN



Page 44

EXTERNAL TOOLHOLDER



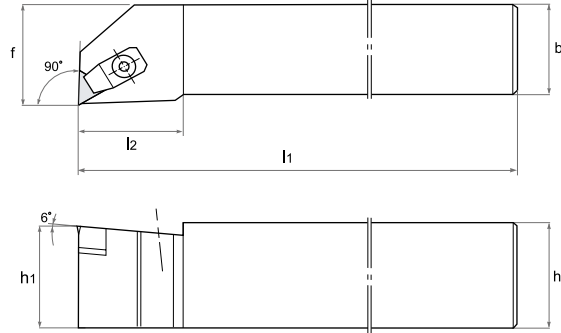

PART.
A

TURNING
&
MILLING

CTFP



Type	Dimensions (mm)					Stock		Insert	Spare Parts			
	h(h ₁)	b	l ₁	l ₂	f	R	L		Clamp & Clamp Screw	Shim	Shim Screw	Wrench
CTFPR/L 2020K16-A3	20	20	125	20	25			TPGN1603	UH1	SHTC3A	SP3	LW4
CTFPR/L 2525M16-A3	25	25	150	20	32			TPGN1603	UH1	SHTC3A	SP3	LW4

Spare parts			
Clamp & Clamp Screw	Shim	Shim Screw	Wrench
			
UH1	SHTC3A	SP3	LW3 LW4

CERAMIC

CERMET

PCBN
/
PCD

TOOL
HOLDER

MILLING
CUTTER

TPGN



Page 48

HRCD

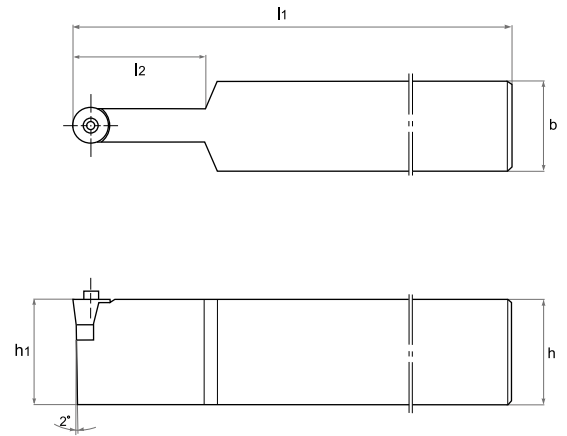
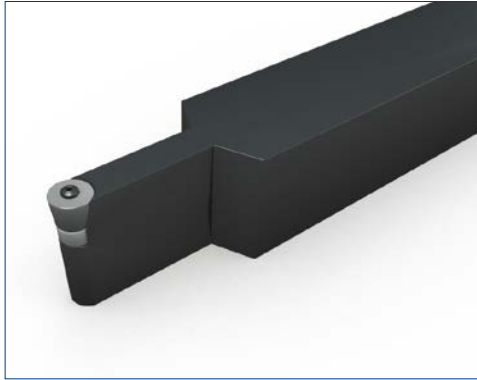

Type	Dimensions [mm]				Stock	Insert	Spare Parts		
	h(h ₁)	b	l ₁	l ₂			Clamp & Clamp Screw	Shim	Wrench
HRCD 2525M12-B6	25	25	150	15	●	CDH1206	HB 2	SHCD22	LW2.5
HRCD 2525M19-B9	25	25	150	15	●	CDH1909	HB 3	SHCD33	LW5
HRCD 3225R19-B9	32	25	200	38	●	CDH1909	HB 3	SHCD33	LW5
HRCD 4035S19-B9	40	35	250	45	●	CDH1909	HB 3	SHCD33	LW5
HRCD 4035S32-B19	40	35	250	45		CDH3219	HB 5	SHCD53	LW6
HRCD 5050T32-B19	50	50	300	50		CDH3219	HB 5	SHCD53	LW6

Spare parts									
Clamp & Clamp Screw			Shim			Wrench			
HB2	HB3	HB5	SHCD22	SHCD33	SHCD53	LW2.5	LW5	LW6	

CERAMIC

CERMET

PCBN
/
PCD

TOOL
HOLDER

MILLING
CUTTER



EXTERNAL TOOLHOLDER

PART.
A

TURNING
&
MILLING

CVJN

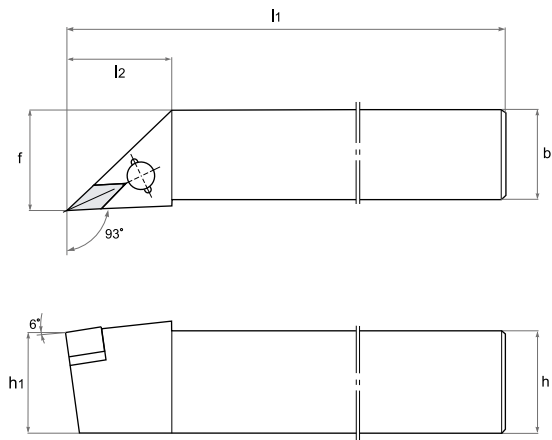

Type	Dimensions (mm)					Stock		Insert	Spare Parts			
	h(h ₁)	b	l ₁	l ₂	f	R	L		Clamp & Clamp Screw	Shim	Shim Screw	Wrench
CVJNR/L 2525M16-A4	25	25	150	41	32	•	•	VNGN1604	SM4	SHVN3A	TM412	LW4
CVJNR/L 2525M16-X7	25	25	150	41	32	•	•	VNGX1607	SM4	SHVN3A	TM412	LW4
CVJNR/L 3225P16-X7	32	25	170	41	32	•		VNGX1607	SM4	SHVN3A	TM412	LW4

Spare parts			
Clamp & Clamp Screw	Shim	Shim Screw	Wrench
SM4	SHVN3A	TM412	LW4

CERAMIC

CERMET

PCBN
/
PCD

TOOL
HOLDER

MILLING
CUTTER

VNGN	VNGX
Page 49	Page 50

CVVN

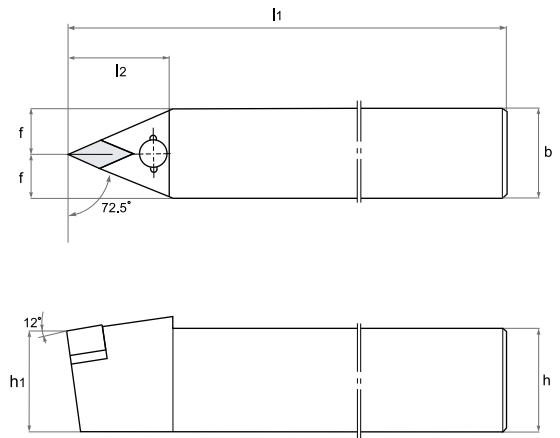

Type	Dimensions [mm]					Stock	Insert	Spare Parts			
	h [h ₁]	b	l ₁	l ₂	f			Clamp & Clamp Screw	Shim	Shim Screw	Wrench
CVVNN 2525M16-A4	25	25	150	45	12.5		VNGN1604	SM4	SHVN3A	TM412	LW4
CVVNN 2525M16-X7	25	25	150	45	12.5		VNGX1607	SM4	SHVN3A	TM412	LW4
CVVNN 3225P16-X7	32	25	170	45	12.5	•	VNGX1607	SM4	SHVN3A	TM412	LW4

Spare parts			
Clamp & Clamp Screw	Shim	Shim Screw	Wrench
SM4	SHVN3A	TM412	LW4

CERAMIC

CERMET

PCBN
/
PCD

TOOL
HOLDER

MILLING
CUTTER

VNGN	VNGX
Page 49	Page 50

EXTERNAL TOOLHOLDER

PART.
A

TURNING
&
MILLING

CSBF

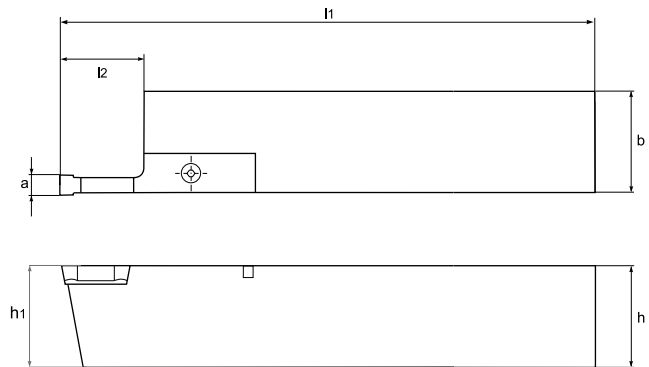

Type	Dimensions (mm)					Stock		Insert	Spare Parts	
	a	h[h ₁]	b	l ₁	l ₂	R	L		Clamp & Clamp Screw	Wrench
CSBF 5040P3228R/L	3.18	50	40	170	19			SYBF3228	SGD3 / BM518	LW3
CSBF 5040P4828R/L	4.78	50	40	170	19			SYBF4828	SGD4 / BM518	LW4
CSBF 5040P5528R/L	5.54	50	40	170	19			SYBF5528	SGD4 / BM518	LW4
CSBF 5040P6428R/L	6.35	50	40	170	19			SYBF6428	SGD6 / BM618	LW4
CSBF 5040P7928R/L	7.93	50	40	170	19			SYBF7928	SGD6 / BM618	LW4
CSBF 5040P9528R/L	9.52	50	40	170	19			SYBF9528	SGD9 / BM1018	LW5

Spare parts										
Clamp & Clamp Screw					Wrench					
SGD3	SGD4	SGD6	SGD9		BM518	BM618	BM1018	LW3	LW4	LW5

CERAMIC

CERMET

PCBN
/
PCD

TOOL
HOLDER

MILLING
CUTTER

SYBF



CSBR

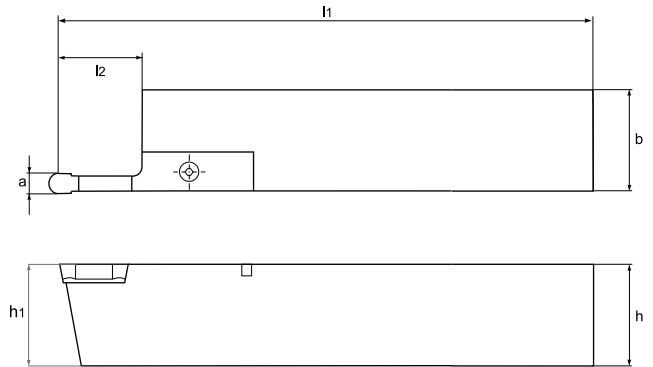

Type	Dimensions [mm]					Stock		Insert	Spare Parts	
	a	h(h ₁)	b	l ₁	l ₂	R	L		Clamp & Clamp Screw	Wrench
CSBR 5040P3228R/L	3.18	50	40	170	19			SYBR3228	SGD3 / BM518	LW3
CSBR 5040P4828R/L	4.78	50	40	170	19			SYBR4828	SGD4 / BM518	LW4
CSBR 5040P5528R/L	5.54	50	40	170	19			SYBR5528	SGD4 / BM518	LW4
CSBR 5040P6428R/L	6.35	50	40	170	19			SYBR6428	SGD6 / BM618	LW4
CSBR 5040P7928R/L	7.93	50	40	170	19			SYBR7928	SGD6 / BM618	LW4
CSBR 5040P9528R/L	9.52	50	40	170	19			SYBR9528	SGD9 / BM1018	LW5

Spare parts									
Clamp & Clamp Screw						Wrench			
SGD3	SGD4	SGD6	SGD9	BM518	BM618	BM1018	LW3	LW4	LW5

CERAMIC

CERMET

PCBN
/
PCD

TOOL
HOLDER

MILLING
CUTTER

SYBR

Page 58

EXTERNAL TOOLHOLDER

PART.
A

TURNING
&
MILLING

CSGF

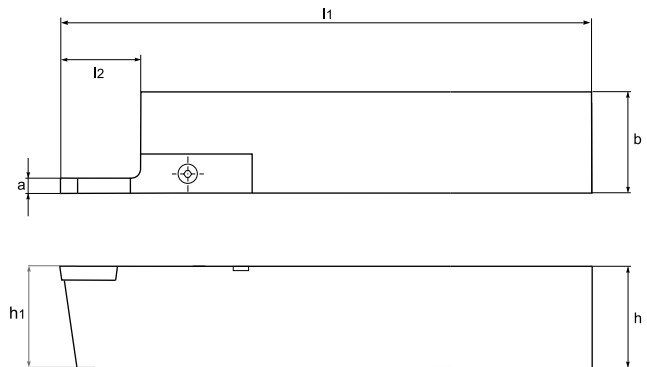

Type	Dimensions (mm)					Stock		Insert	Spare Parts	
	a	h[h ₁]	b	l ₁	l ₂	R	L		Clamp & Clamp Screw	Wrench
CSGF 3225P4012R/L	4.0	32	25	170	19	•		SGF4012	SGL4 / BM518	LW3
CSGF 3225P5012R/L	5.0	32	25	170	19	•		SGF5012	SGL5 / BM518	LW4
CSGF 3225P6015R/L	6.0	32	25	170	19	•	•	SGF6015	SGL5 / BM518	LW4
CSGF 3225P7015R/L	7.0	32	25	170	19	•		SGF7015	SGL7 / BM618	LW5
CSGF 3225P8015R/L	8.0	32	25	170	19	•	•	SGF8015	SGL8 / BM618	LW5
CSGF 3225P1015R/L	10.0	32	25	170	19			SGF1015	SGL8 / BM618	LW5

Spare parts									
Clamp & Clamp Screw					Wrench				
SGL4	SGL5	SGL7	SGL8		BM518	BM618	LW3	LW4	LW5

CERAMIC

CERMET

PCBN
/
PCD

TOOL
HOLDER

MILLING
CUTTER

SGF



Page 59

CSGR

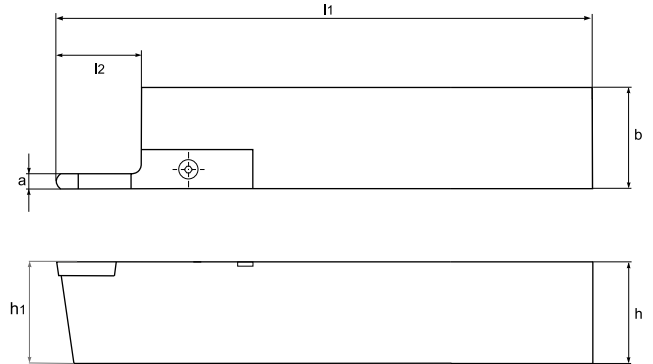

Type	Dimensions [mm]					Stock		Insert	Spare Parts	
	a	h(h ₁)	b	l ₁	l ₂	R	L		Clamp & Clamp Screw	Wrench
CSGR 3225P4012R/L	4.0	32	25	170	19		•	SGR4012	SGL4 / BM518	LW3
CSGR 3225P5012R/L	5.0	32	25	170	19	•		SGR5012	SGL5 / BM518	LW4
CSGR 3225P6015R/L	6.0	32	25	170	19			SGR6015	SGL5 / BM518	LW4
CSGR 3225P7015R/L	7.0	32	25	170	19			SGR7015	SGL7 / BM618	LW5
CSGR 3225P8015R/L	8.0	32	25	170	19			SGR8015	SGL8 / BM618	LW5
CSGR 3225P1015R/L	10.0	32	25	170	19			SGR1015	SGL8 / BM618	LW5

Spare parts									
Clamp & Clamp Screw					Wrench				
SGL4	SGL5	SGL7	SGL8		BM518	BM618	LW3	LW4	LW5

CERAMIC

CERMET

PCBN
/
PCD

TOOL
HOLDER

MILLING
CUTTER



EXTERNAL TOOLHOLDER

PART.
A

TURNING
&
MILLING

CSSF

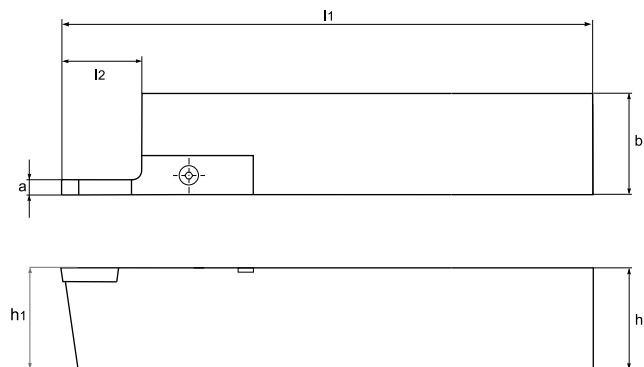

Type	Dimensions (mm)					Stock		Insert	Spare Parts	
	a	h[h ₁]	b	l ₁	l ₂	R	L		Clamp & Clamp Screw	Wrench
CSSF 3225P4012R/L	4.0	32	25	170	19	•	•	SSF4012	SGL4 / BM518	LW3
CSSF 3225P5012R/L	5.0	32	25	170	19	•		SSF5012	SGL5 / BM518	LW4
CSSF 3225P6015R/L	6.0	32	25	170	19	•		SSF6015	SGL5 / BM518	LW4
CSSF 3225P7015R/L	7.0	32	25	170	19			SSF7015	SGL7 / BM618	LW5
CSSF 3225P8015R/L	8.0	32	25	170	19			SSF8015	SGL8 / BM618	LW5
CSSF 3225P1015R/L	10.0	32	25	170	19			SSF1015	SGL8 / BM618	LW5

Spare parts									
Clamp & Clamp Screw					Wrench				
SGL4	SGL5	SGL7	SGL8	BM518	BM618	LW3	LW4	LW5	

CERAMIC

CERMET

PCBN
/
PCD

TOOL
HOLDER

MILLING
CUTTER

SSF



Page 60

CSSR

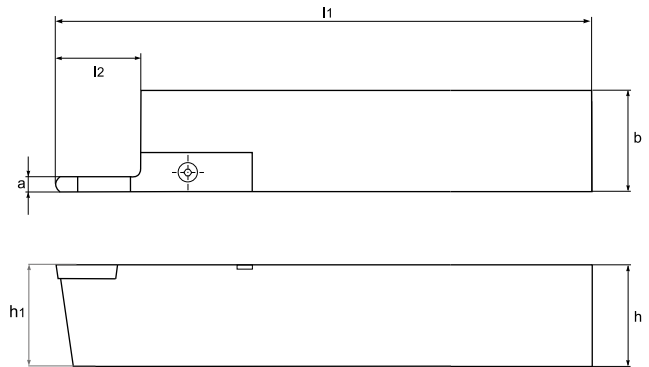

Type	Dimensions [mm]					Stock		Insert	Spare Parts	
	a	h(h ₁)	b	l ₁	l ₂	R	L		Clamp & Clamp Screw	Wrench
CSSR 3225P4012R/L	4.0	32	25	170	19			SSR4012	SGL4 / BM518	LW3
CSSR 3225P5012R/L	5.0	32	25	170	19	•		SSR5012	SGL5 / BM518	LW4
CSSR 3225P6015R/L	6.0	32	25	170	19	•		SSR6015	SGL5 / BM518	LW4
CSSR 3225P7015R/L	7.0	32	25	170	19			SSR7015	SGL7 / BM618	LW5
CSSR 3225P8015R/L	8.0	32	25	170	19	•		SSR8015	SGL8 / BM618	LW5
CSSR 3225P1015R/L	10.0	32	25	170	19			SSR1015	SGL8 / BM618	LW5

Spare parts									
Clamp & Clamp Screw						Wrench			
SGL4	SGL5	SGL7	SGL8	BM518	BM618	LW3	LW4	LW5	

CERAMIC

CERMET

PCBN
/
PCD

TOOL
HOLDER

MILLING
CUTTER

SSR

Page 60

EXTERNAL TOOLHOLDER

PART.
A

CSSR .. N

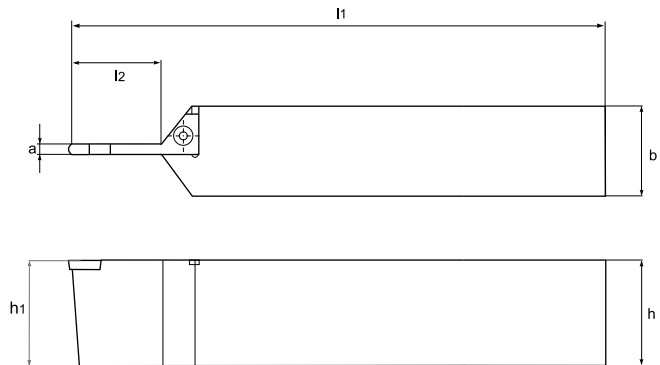

TURNING
&
MILLING

Type	Dimensions (mm)					Stock	Insert	Spare Parts	
	a	h[h ₁]	b	l ₁	l ₂			Clamp & Clamp Screw	Wrench
CSSR 4040R4012.N5	4.0	40	40	200	5		SSR4012	GRW4012 / BM518	LW3
CSSR 5040P4012.N19	4.0	50	40	170	19		SSR4012	GRW4012 / BM518	LW3

Spare parts		
Clamp & Clamp Screw	Wrench	
GRW4012	BM518	LW4

CERAMIC

CERMET

PCBN
/
PCD

TOOL
HOLDER

MILLING
CUTTER

SSR



Page 60

CBF/R

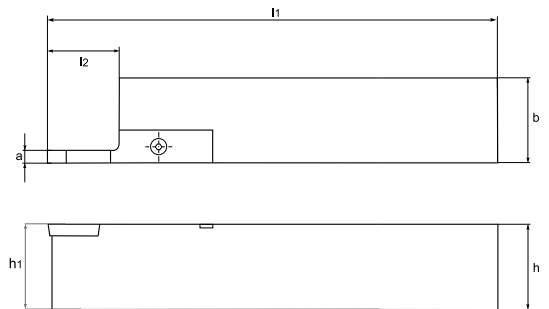

Type	Dimensions (mm)					Stock		Insert	Spare Parts		
	a	h(h ₁)	b	l ₁	l ₂	R	L		Clamp & Clamp Screw	Spring	Wrench
CBF/R 2525M094050R/L	2.3	25	25	150	19			WFP094050 WRP094050 WFC094050 WRC094050	WGL2.3 R/L & WCB6	WCS6	LW5
CBF/R 2525M125050R/L	3.1	25	25	150	19	•	•	WFP125050 WRP125050 WFC125050 WRC125050	WGL3.1 R/L & WCB6	WCS6	LW5
CBF/R 2525M156050R/L	3.9	25	25	150	19	•	•	WFP156050 WRP156050 WFC156050 WRC156050	WGL3.9 R/L & WCB6	WCS6	LW5
CBF/R 2525M187050R/L	4.7	25	25	150	19	•	•	WFP187050 WRP187050 WFC187050 WRC187050	WGL4.7 R/L & WCB6	WCS6	LW5
CBF/R 2525M218075R/L	5.5	25	25	150	29	•		WFP218075 WRP218075 WFC218075 WRC218075	WGL5.5 R/L & WCB6	WCS6	LW5
CBF/R 2525M250075R/L	6.3	25	25	150	29	•	•	WFP250075 WRP250075 WFC250075 WRC250075	WGL6.3 R/L & WCB6	WCS6	LW5
CBF/R 2525M281075R/L	7.1	25	25	150	29			WFP281075 WRP281075 WFC281075 WRC281075	WGL7.1 R/L & WCB6	WCS6	LW5
CBF/R 2525M312100R/L	7.9	25	25	150	38			WFP312100 WRP312100 WFC312100 WRC312100	WGL7.9 R/L & WCB6	WCS6	LW5
CBF/R 2525M344100R/L	8.7	25	25	150	38			WFP344100 WRP344100 WFC344100 WRC344100	WGL8.7 R/L & WCB6	WCS6	LW5
CBF/R 2525M375100R/L	9.5	25	25	150	38			WFP375100 WRP375100 WFC375100 WRC375100	WGL9.5 R/L & WCB6	WCS6	LW5

CERAMIC

CERMET

PCBN
/
PCD

TOOL
HOLDER

MILLING
CUTTER

Spare parts			
Clamp & Clamp Screw		Spring	Wrench
WGL2.3 R/L ~ WGL9.5 R/L	WCB6	WCS6	LW5

SPECIAL TOOLHOLDER



PART.
A

TURNING
&
MILLING

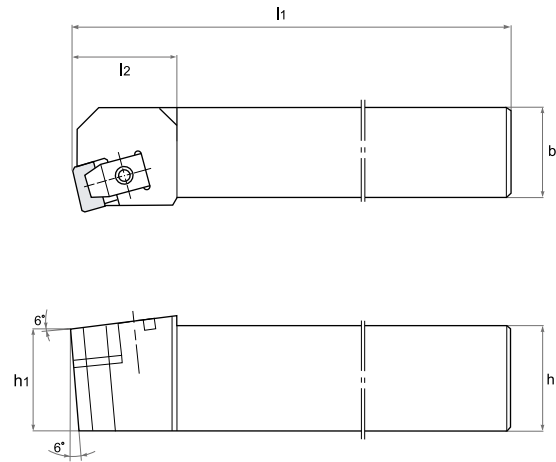
CLKN

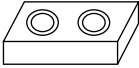

Type	Dimensions (mm)				Stock		Insert	Spare Parts			
	h(h ₁)	b	l ₁	l ₂	R	L		Clamp & Clamp Screw	Shim	Shim Screw	Wrench
CLKNR/L 6060V65-A	60	60	400	70			LNJ6588	UH25	SHLJ65	BM510	LW6
CLKNR/L 6060V66-A	60	60	400	70			LNJ6688	UH25	SHLJ66	BM510	LW6

Spare parts				
Clamp & Clamp Screw	Shim		Shim Screw	Wrench
				
UH25	SHLJ65	SHLJ66	BM510	LW6

CERAMIC

CERMET

PCBN
/
PCD

TOOL
HOLDER

MILLING
CUTTER

LNJ



Page 55

CFLN

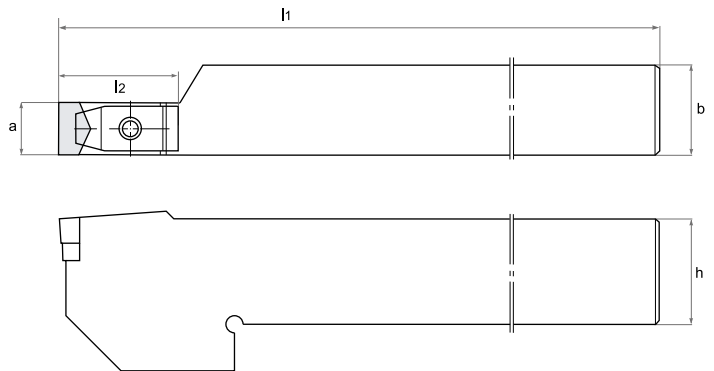

Type	Dimensions [mm]					Stock	Insert	Spare Parts			
	a	h(h ₁)	b	l ₁	l ₂			R	Clamp & Clamp Screw	Shim	Shim Screw
CFLNN 6060U44-A	14	60	60	350	80		F10537	UH25	SHF10	BM510	LW6
CFLNN 5050T32-A	12	50	50	300	75		F13941	UH25	SHF13	BM510	LW6
CFLNN 4040R25-A	7	40	40	200	40		F250723	UH4	SHF25	BM510	LW4

Spare parts						
Clamp & Clamp Screw		Shim			Shim Screw	Wrench
UH4	UH25	SHF10	SHF13	SHF25	BM510	LW8

CERAMIC

CERMET

PCBN
/
PCD

TOOL
HOLDER

MILLING
CUTTER

F-Series	F-Series
Page 53	Page 54

SPECIAL TOOLHOLDER

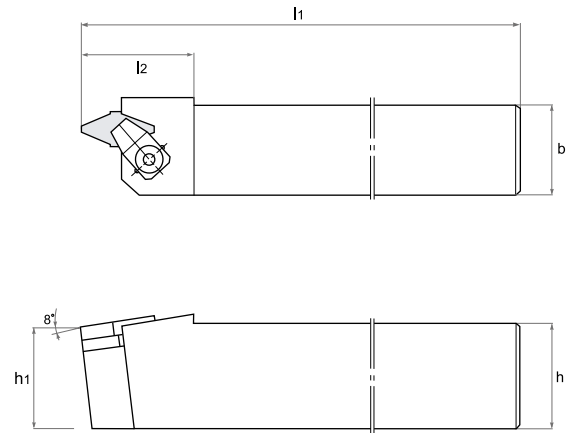

PART.
A

CSVN

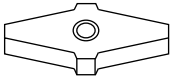

TURNING
&
MILLING

Type	Dimensions (mm)				Stock	Insert	Spare Parts			
	h(h ₁)	b	l ₁	l ₂			R	Clamp & Clamp Screw	Shim	Shim Screw
CSVNN 3232P38-A7-26	32	32	170	38		SVW38260	UH1	SHSV3826	FM510	LW4
CSVNN 3232P38-A7-32	32	32	170	40		SVW38320	UH1	SHSV3832	FM510	LW4
CSVNN 3232P34-A7-40	32	32	170	50		SVW34400	UH1	SHSV3440	FM510	LW4

Spare parts					
Clamp & Clamp Screw	Shim			Shim Screw	Wrench
					
UH1	SHSV3826	SHSV3832	SHSV3440	FM510	LW4

CERAMIC

CERMET

PCBN
/
PCD

TOOL
HOLDER

MILLING
CUTTER

SVW



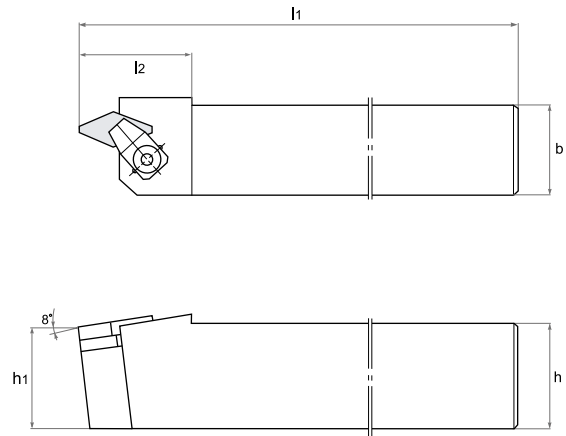

Page 77

CGVN

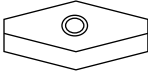

Type	Dimensions [mm]				Stock	Insert	Spare Parts			
	h(h ₁)	b	l ₁	l ₂			Clamp & Clamp Screw	Shim	Shim Screw	Wrench
CGVNN 3232P38-A7-32	32	32	170	48		GVGN38320	UH1	SHGV3832	FM510	LW4
CGVNN 3232P38-A7-33	32	32	170	46		GVGN38335	UH1	SHGV3833	FM510	LW4
CGVNN 3232P36-A7-34	32	32	170	49		GVGN36340	UH1	SHGV3634	FM510	LW4
CGVNN 3232P38-A7-36	32	32	170	44		GVGN38360	UH1	SHGV3836	FM510	LW4
CGVNN 3232P34-A7-36	32	32	170	44		GVGN34360	UH1	SHGV3436	FM510	LW4

Spare parts				
Clamp & Clamp Screw	Shim		Shim Screw	Wrench
				
UH1	SHGV3832 SHGV3836	SHGV3833 SHGV3436	SHGV3634	FM510
				LW4

CERAMIC

CERMET

PCBN
/
PCD

TOOL
HOLDER

MILLING
CUTTER

GVGN



Page 77

SPECIAL TOOLHOLDER



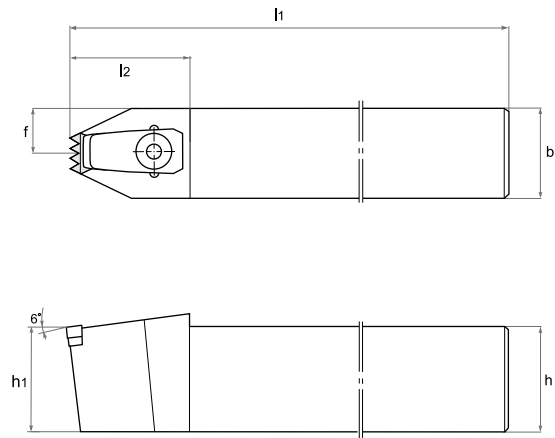

PART.
A

CINN



TURNING
&
MILLING

Type	Dimensions (mm)					Stock	Insert	Spare Parts			
	h(h ₁)	b	l ₁	l ₂	f			Clamp & Clamp Screw	Shim	Shim Screw	Wrench
CINNN 2525M09-A4-F3	25	25	150	30	12.5	●	INGN160435F3	UH1	SHIN33F3	TM3008	LW4
CINNN 2525M12-A4-F4	25	25	150	34	12.5	●	INGN220435F4	UH1	SHIN43F4	TM4010	LW4
CINNN 3225P09-A4-F3	32	25	170	30	12.5		INGN160435F3	UH1	SHIN33F3	TM3008	LW4
CINNN 3225P12-A4-F4	32	25	170	34	12.5		INGN220435F4	UH1	SHIN43F4	TM4010	LW4

Spare parts				
Clamp & Clamp Screw	Shim		Shim Screw	Wrench
				
UH1	SHIN33F3	SHIN43F4	TM3008	TM4010
				LW4

CERAMIC

CERMET

PCBN
/
PCD

TOOL
HOLDER

MILLING
CUTTER

